

Get Your Physical Copy at:

<https://www.amazon.ca/Guitar-Scales-Practical-Understanding-Fretboard/dp/1495902277/>

3 reviews ★★★★★

Table of Contents

The Guitar Fretboard Diagram	9		
Introduction	2	Questions 3	36
How To Practice	3	The Minor Pentatonic Scale	37
Introduction to Scales	4	The A Minor Pentatonic Scale, Vertical Forms	38
How Scales Work on the Guitar Fretboard	5	Chord Diagrams	40
The C Major Scale	6	Chord Progressions	41
Questions 1	8	Alternate C Major Scale Fingerings	43
		Playing Scales Horizontally	44
The C Major Scale on the Master Fretboard	10	C Major II - V Position	45
Scale and Fretboard Position	11	Scale Shifts - 2-Octave Scales	46
C Major Scale - I Position	13	C Major II - VII PositionForms	47
- II Position	14	The G Major Scale	48
- V Position	15	G Major Scale - All Positions	50
- VII Position	16	E Natural Minor Scale - All Positions	51
- IX Position	17	G Major Pentatonic Scale - All Positions	52
- XII Position	18	Moving and Renaming the Vertical Scale	53
The Natural Minor Scale	19	Root 5 String - Major Scale	54
C Major (C Tonic) Key of C	20	Root 6 String - Major Scale	55
The Relative Minor	21	Root 6 String - Natural Minor Scale	56
Questions 2	22	Root 5 String - Natural Minor Scale	57
A Natural Minor Scale - I Position	23	Root 4 String - Major Pentatonic Scale	58
- II Position	24	Root 6 String - Minor Pentatonic Scale	59
- V Position	25	Questions 4	60
- VII Position	26	Master Fretboard	62
- IX Position	27	Major Scales Reference Sheet	63
- XII Position	28	Glossary of Terms	64
The Major Pentatonic Scale	29	Answers	67
C Major Pentatonic Scale - I Position	30	About The Author	69
- II Position	31		
- V Position	32		
- VII Position	33		
- IX Position	34		
- XII Position	35		

INTRODUCTION

This is a unique approach to method book instruction. Each book is presented in a logical step-by-step format leading to a "practical" understanding of one area of guitar study. The purpose is not to relate a lot of information on the topic of guitar playing, but instead to build a solid foundation on which the student and player can build, both in practical hands-on application and practical theory and understanding. This approach can be used successfully with the student guiding him or herself through the series or as a teaching method for instructors.

Each page is presented as a lesson within a lesson and is visually clear with lots of tips, clues and background. The entire series has been dry-run through thousands of private lessons with real results before going to print.

For further study of harmony for guitar, see "Triads For Guitar" and "Arpeggios For Guitar" by Lloyd English available as digital download or Print On Demand at Amazon.com.

Online video lessons with Lloyd English are available at www.MyGuitarPal.com



**LEARN TO PLAY GUITAR
FOR ONLY \$1!**

The fastest, easiest and most effective course available online that will transform you from beginner to confident player in 30 days!

[Learn More](#)

Copyright ©2013 by My Pal Online Education Inc.

www.myguitarpal.com

All rights reserved. No part of this book may be reproduced in any form or by any electronic or mechanical means including information storage and retrieval systems, without permission in writing from the publisher except by a reviewer who may quote brief passages in a review.

HOW TO PRACTICE

When you begin to practice your scales take the following to heart and you will save yourself a lot of frustration and wasted time.

Practicing is programming your body to repeat exactly what you are putting in, automatically. If you are putting in mistakes your body will remember those with the same efficiency as correct notes, so please follow this type of routine.

1. Choose a task to practice and allow a time frame for it, let's say 10 minutes.
2. Play the exercise only at a speed (tempo) at which you are not making mistakes!
3. Continue to repeat the scale as you would repetitions of push-ups or sit-ups, consider it an exercise. Repetitions should be done slowly and accurately with concentration. Follow fingerings carefully and keep them identical ascending and descending.
4. If you get bored, stop and go on to something else. Be able to concentrate for the duration of the time frame. Remember, you are also working on your ability to concentrate. Everything that is worthwhile takes discipline and care.
5. Make sure your guitar is in tune. If it isn't you are sending you ears all sorts of wrong information. If you are unsure invest in an electronic tuner.

I assure you this is a tried and true and accepted method, please follow it diligently and you will see results. What you are doing is putting together the tools required to play. Enjoy the process!

TASK - TIMEFRAME - CONCENTRATION - REPETITION

INTRODUCTION TO SCALES

Virtually all the music you listen to is in one way or another based on scales. Scales are a way of organizing notes so that they make musical sense to our ears. Over centuries, scales and their use have developed into what we now accept as certain norms for our music in western culture.

There are many different kinds of scales: major, minor, pentatonic, whole tone, diminished, modes, and more exotic ones such as tone rows, blues, modes, altered chord scales, and on and on.

What I am primarily concerned with in "Scales For Guitar" is to give the student a "practical" understanding of scales, not only providing a basic working knowledge of how scales are formed, but how to use them in an improvisational context as well.

Exercises presented in this book will also be very useful to the classical student who wishes to have a comprehensive understanding of fretboard harmony and mechanics.

Scales work as systems and the guitar fretboard is efficiently organized by those systems. Harmony, in turn, combines scale notes into interval and chord sounds. Together, these melodic and harmonic relationships provide us with the raw materials for music making.

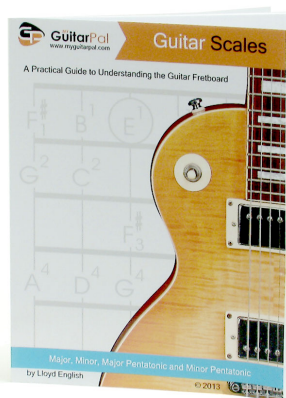

Get Your Physical Copy at:

<https://www.amazon.ca/Guitar-Scales-Practical-Understanding-Fretboard/dp/1495902277/>

3 reviews ★★★★★

HOW SCALES WORK ON THE GUITAR FRETBOARD

A scale is a group of related notes organized in an ascending or descending order from a starting note, in other words, a ladder of notes. The two most common scale sounds are called major and minor. The difference between these two scale sounds is in the distances between the notes.

The most common scale sound is the do re mi fa so la ti do scale, the major scale. In order to come to a more complete understanding of what that means we must examine the notes' relationships to each other, for example, from do to re, or from ti to do.

Let's write down a representation of the scale in music notation, starting on the "root" note C.

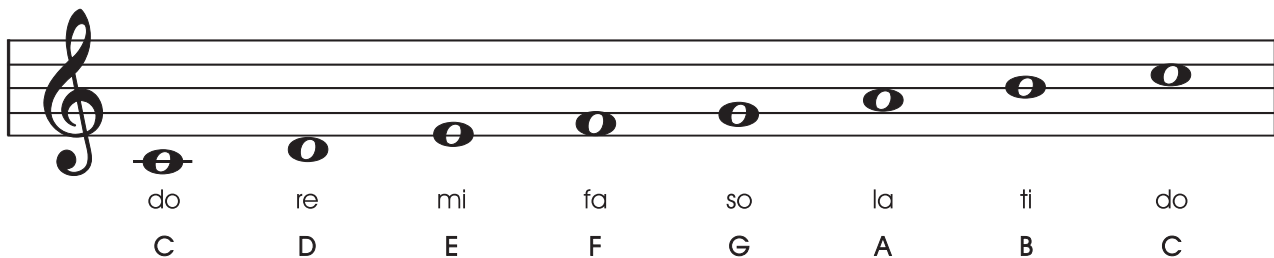

C to D on the guitar fretboard is 2 frets, this distance is referred to as a "tone." D to E is also 2 frets, also a "tone." E to F is only a single fret distance. This is a "semi-tone" or half a tone. F to G is a tone, G to A is a tone, A to B is a tone and once again, B to C is a semi-tone.

Therefore, a major scale is made up of the following distances between the notes.

Tone Tone Semi-tone Tone Tone Tone Semi-tone

Get Your Physical Copy at:
<https://www.amazon.ca/Guitar-Scales-Practical-Understanding-Fretboard/dp/1495902277/>

Learn to Play Guitar for \$1
<http://myguitarpal.com/beginner-guitar/>

THE C MAJOR SCALE

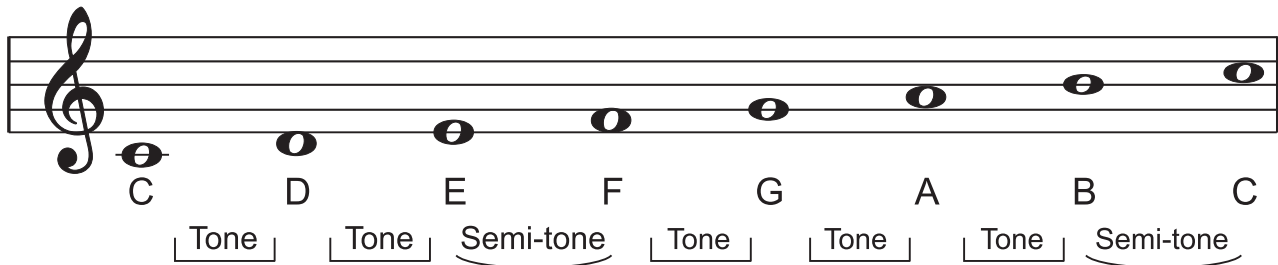

So now this can be said about a major scale; it is a tone, tone, semi-tone, tone, tone, tone, semi-tone scale. This pattern of distances can start from any given note. If we start on a C note (TTSTTTTS) we call that scale C major. If we begin those same distances starting on a G note, G major, from D, D major and so on. The notes will be different but the distances between the notes will be the same. (See the scale reference sheet on page 66.)

This can be illustrated by playing a major scale on a single string. Starting on the open high E string, play the TTSTTTTS relationship. Don't worry about fingering for now. Just use finger 1, the index finger.

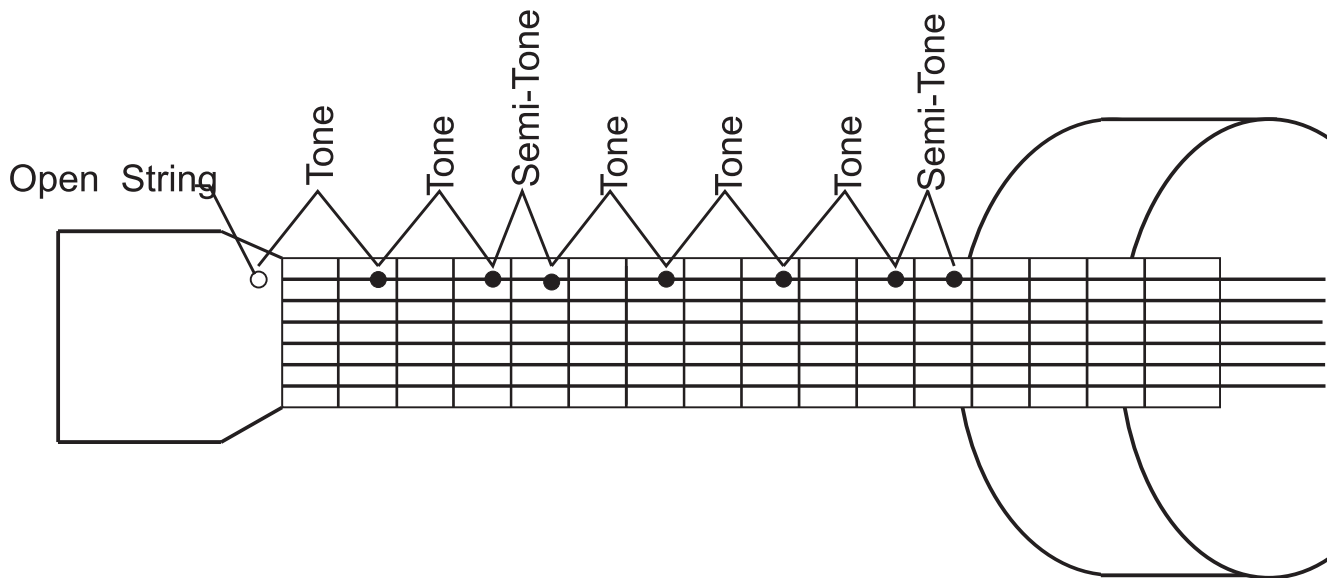

This is an E major scale. It is not all that practical, but it does demonstrate the principle of constructing a scale. Do the same exercise starting on any note. Remember that the starting note names the scale. Two common names for the starting note are "root" and "tonic."

The starting note or root note is the gravitational centre of the scale, and the other notes are attracted to the tonic or "key" centre. The C scale is said to be in the "key of C." The E scale, in the "key of E" and so on.

I hope this helps to clear up in your mind what a scale is: a group of notes organized by distances in an ascending or descending order from a starting note or tonal centre or "key" centre.

Let's examine how these relationships of notes are expressed on the guitar fretboard.

First, there are only seven different notes in this scale with the repeat of the first note completing the scale; this distance of eight notes is called an "octave."

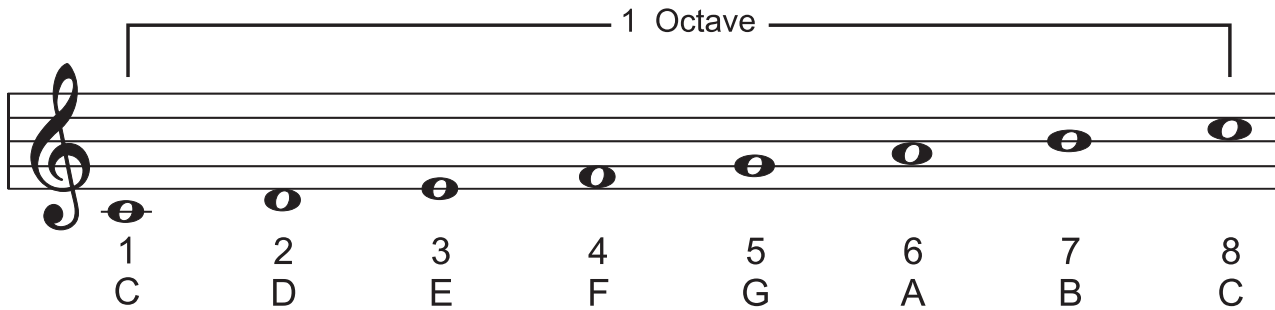

These notes can be continued through several octaves depending on the range of the instrument. Notice that the notes have the same letter names, but are played in different octaves.

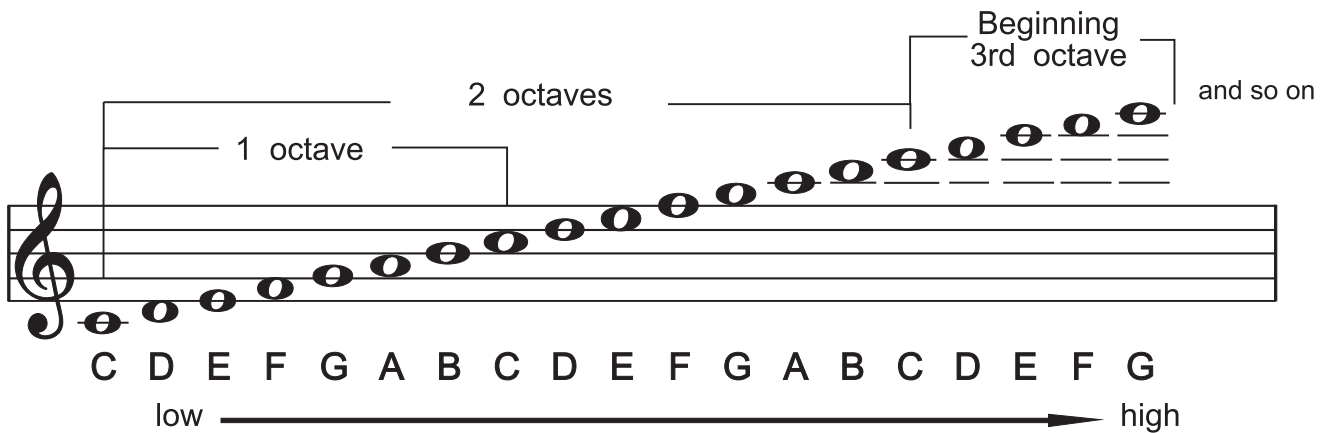

Scales are often practiced starting on the root note, then ascending through 1 or 2 or 3 octaves and then descending in the same order back to the tonic. This is good practice and will be discussed in greater detail later.

What we will examine now is the location of all the notes of the C major scale on the fretboard. But first, a few questions.

Questions 1

1. What is a scale? _____
2. What is a tone? _____
3. What is a semi-tone? _____
4. How many notes in a one-octave major scale? _____
5. How many different notes in a major scale? _____
6. What are the two most common scale sounds? _____
7. Write a major scale according to distances only _____
8. What does "root" mean? _____
9. What does "tonic" mean? _____
10. What is an octave _____
11. What is a key? _____
12. If you heard one note and one note only, could you identify the scale? _____
13. As we ascend a scale, the pitches (notes) get ____higher ____lower
14. As we descend a scale the pitches (notes) get ____higher ____lower
15. If we start the TTSTTTS scale from an "A" note, what would the name of the scale be? _____
16. How many octaves would you say is the "range" of the guitar from lowest note to highest? _____

Answers at the end of the book.

THE GUITAR FRETBOARD DIAGRAM

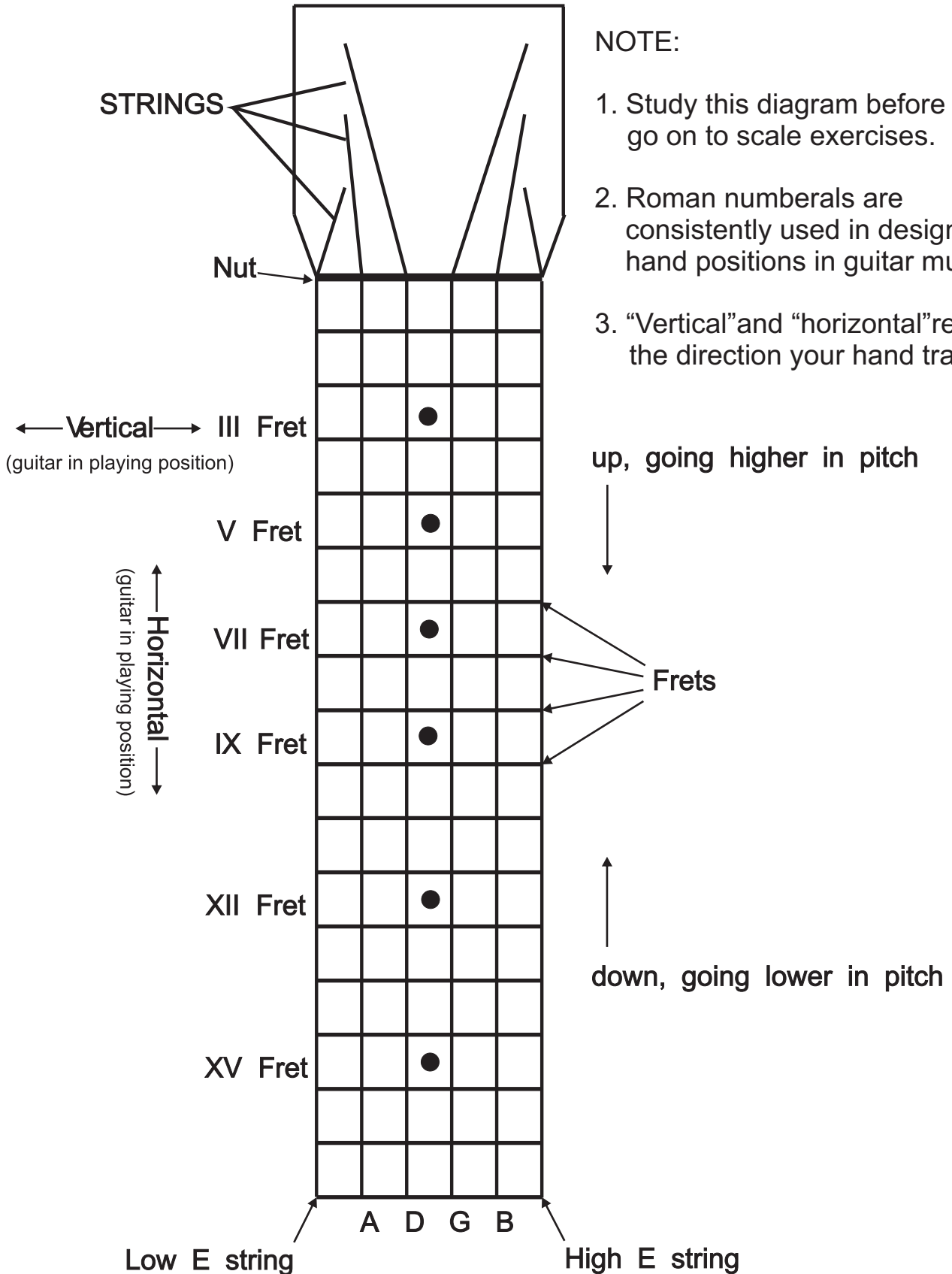

NOTE:

1. Study this diagram before you go on to scale exercises.
2. Roman numerals are consistently used in designating hand positions in guitar music.
3. "Vertical" and "horizontal" refer to the direction your hand travels.

THE C MAJOR SCALE ON THE MASTER FRETBOARD

Below are all the notes of the C major scale, C D E F G A B C. The C root notes are in shaded circles.

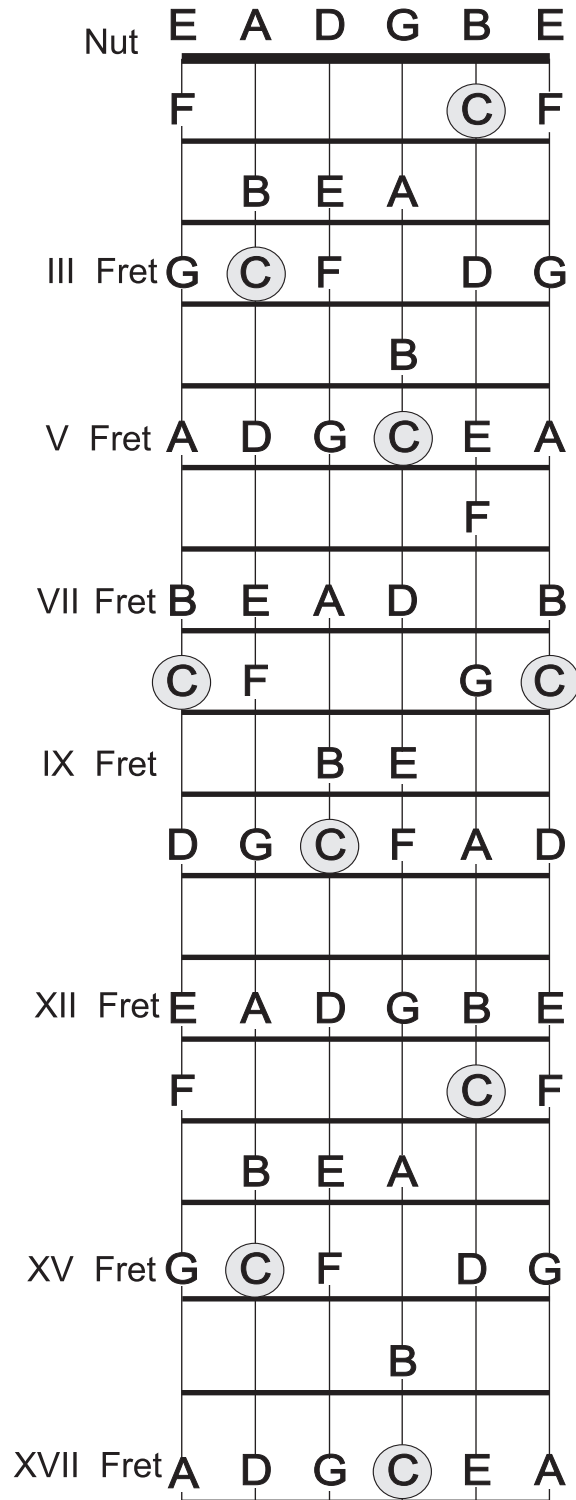

SCALE AND FRETBOARD POSITION

The fret number your index finger is on indicates the scale's position. Positions are indicated with Roman Numerals. Ex. I, II, III, IV, etc.

C major scale in 1st position means index finger at fret I, middle finger at fret II, ring finger at fret III, pinky at fret IV.

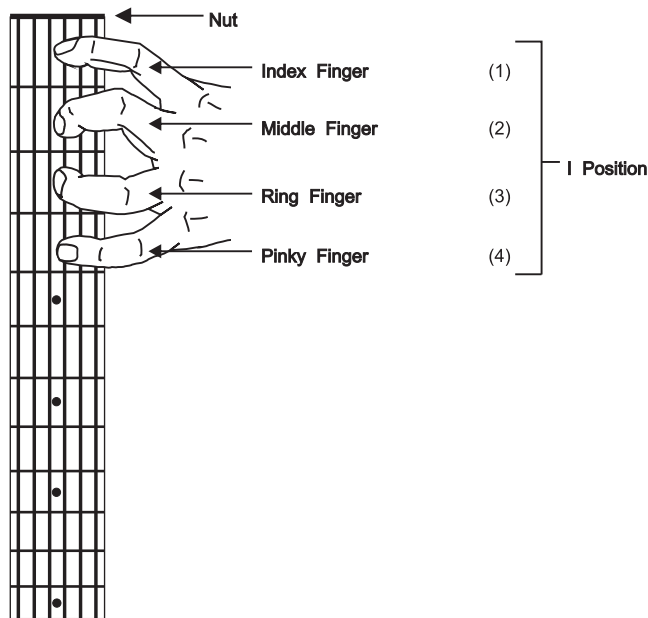

C major scale in II position means index finger at fret II, middle finger at fret III, ring finger at fret IV, pinky at fret V.

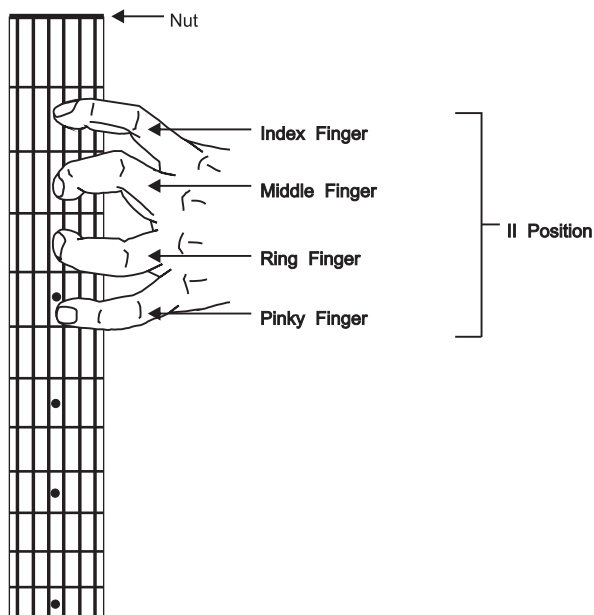

A "shift" means a change of hand position, for instance, from II position to III position during the execution of a scale.

A "stretch" means to stretch the fingers past the four fret four-fingers margin without leaving hand position

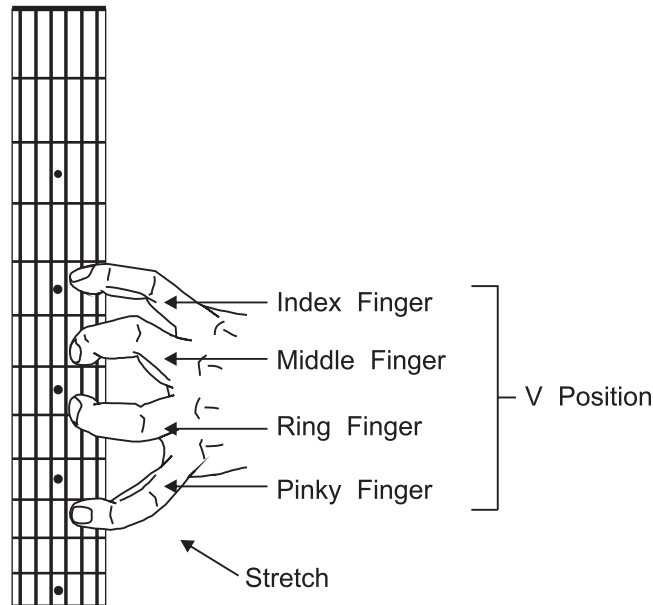

Vertical scale fingerings: Generally not moving out of hand position.

Horizontal scale fingerings: Scales that change position moving laterally across the fretboard, shifting positions as a matter of course. For now we will be dealing with Vertical forms.

Finger numbers:	Index	1
	Middle	2
	Ring	3
	Pinky	4

Strings: Numbered with a circle ①②③ etc.

The following pages illustrate each of the C major vertical scale fingerings as well as the corresponding tonic chord diagram for that position. The chord tones of each chord are indicated by the shaded grey circle in the notation at the bottom of the page.

Read through the notes for fingering and technique tips. Run through each scale form slowly and accurately beginning and ending on the tonic or root note. If you do not start and end on the tonic or root note, the "tonality" of the scale will be confused and will sound wrong because the relationships will be heard from a different tonal centre.

With each of the scale forms learn the chord form as well.

C MAJOR SCALE

I POSITION

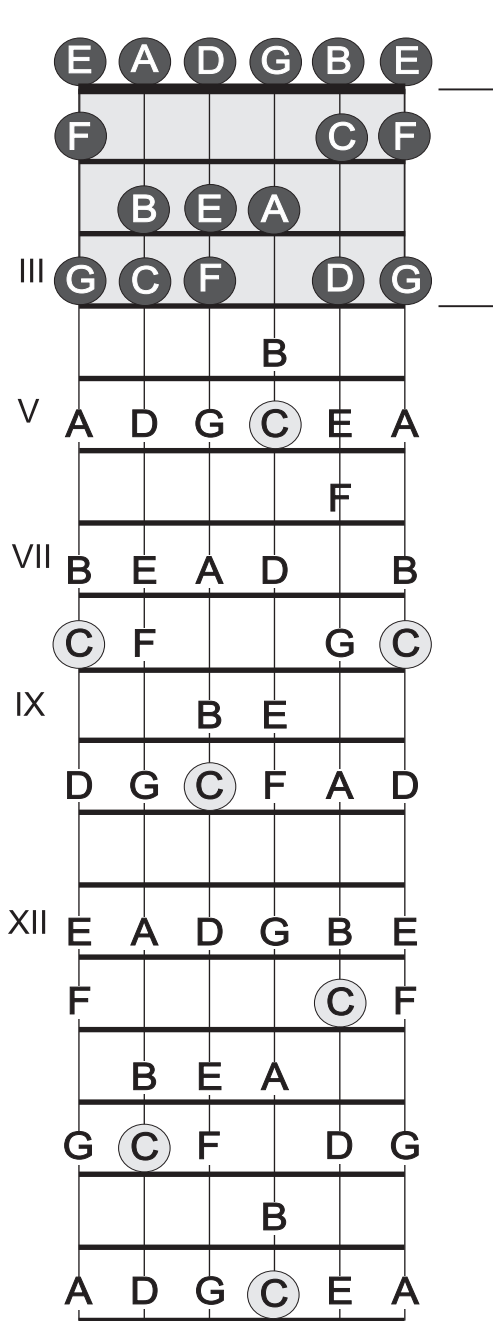

I Position

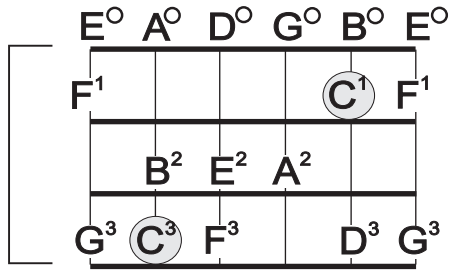

Open Pos.

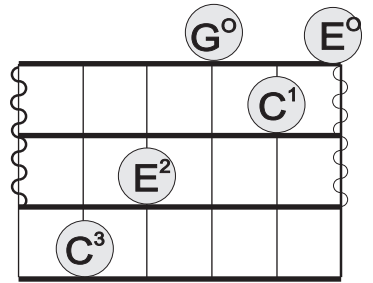

Tonic Chord

Start and end on Root,
Fingerings marked.
O = open string.

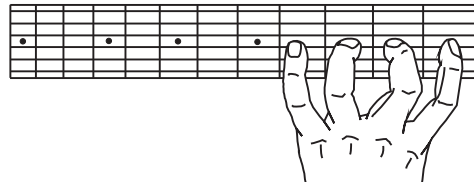

I Position

NOTE:

1. Starts 3rd fret, therefore, finger 3. Play the notes in position in their alphabetical order covering every note in the position and returning to the root. Keep your ears connected to your fingers.
2. Repeat this process 10-20 times. The importance of this kind of practice will become more and more clear. Remember, one finger for each fret.
3. Practice all your scales ascending and descending using the same fingering.

As written:

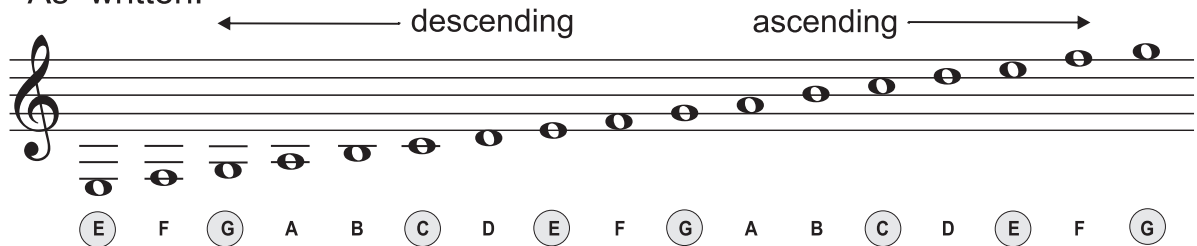

Chord tones circled

start

C MAJOR SCALE

II POSITION

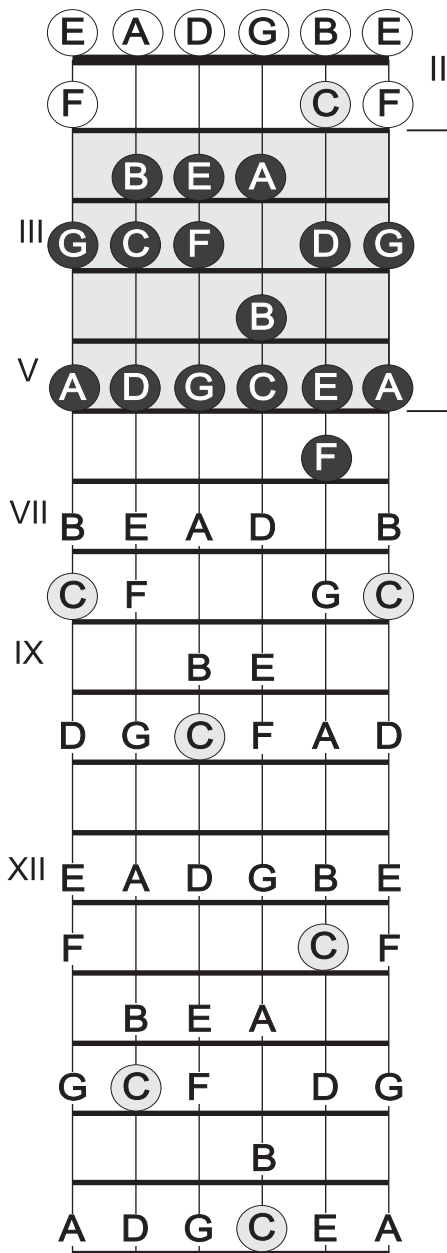

II Position

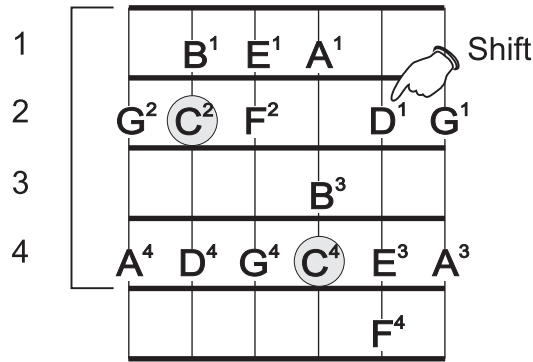

III Pos.

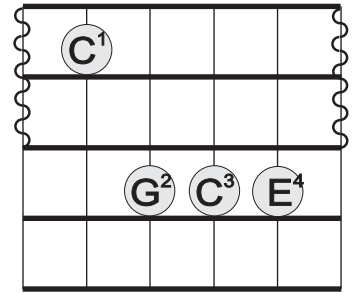

Tonic Chord

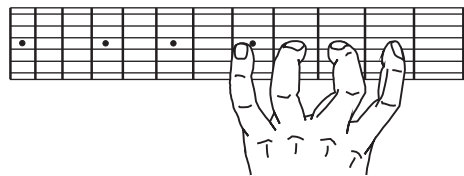

II Position

NOTE:

1. No open strings, shift at string II to position III.
2. Remember to always play your scales with identical fingerings ascending and descending and beginning and ending on the lowest root note C.

As written: ← descending ascending →

Chord tones circled

C MAJOR SCALE

V POSITION

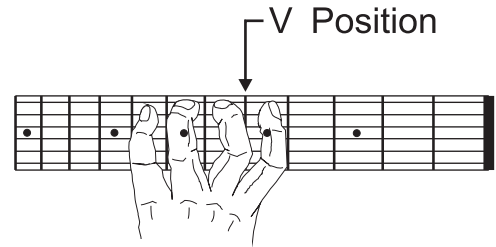
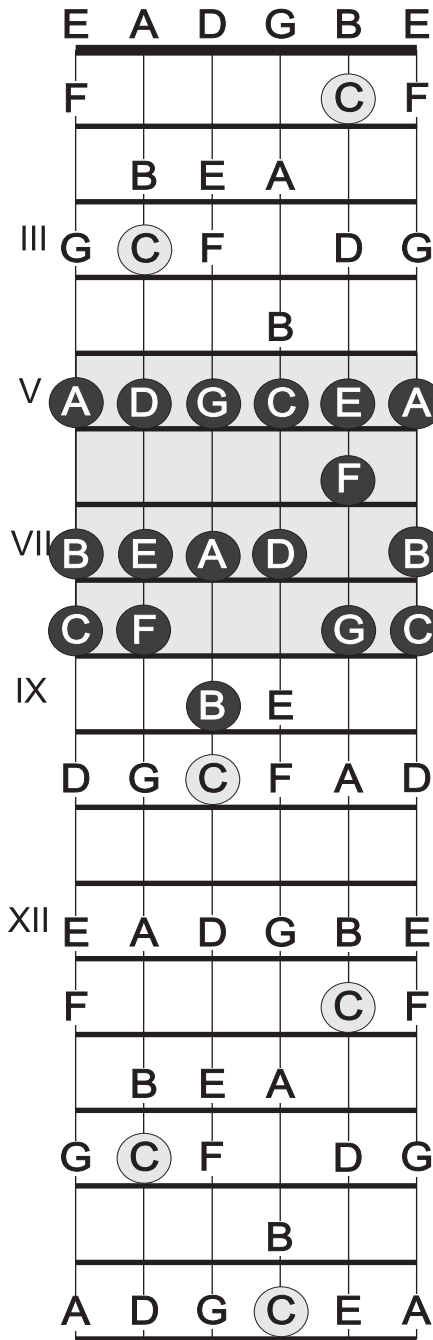

V Position

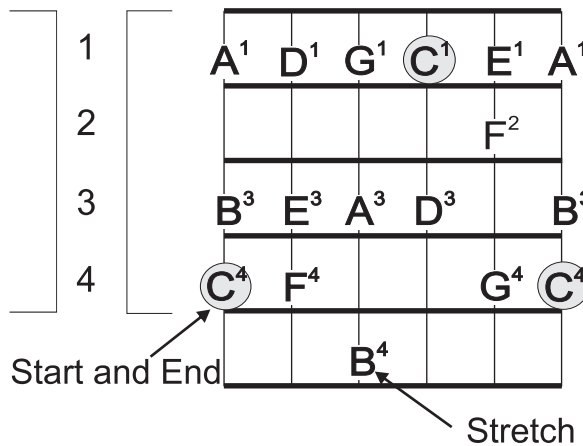

V Position

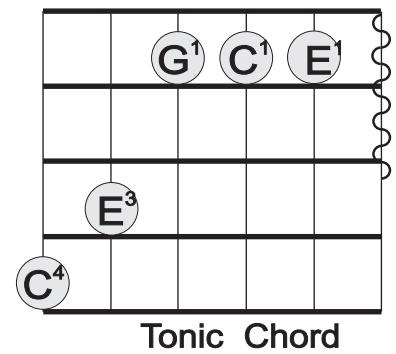

NOTE:

1. Stretch at string 4 to B with finger 4. Do not jump with your hand.
2. Positions III and IV are not necessary to encompass all the notes in the scale. Some other positions will be explained later, at present we will deal with the most common and essential scale forms.

As written: ← descending

ascending →

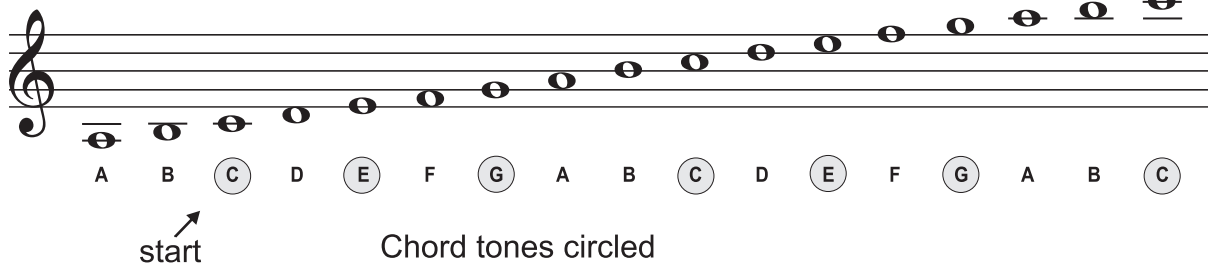

C MAJOR SCALE

VII POSITION

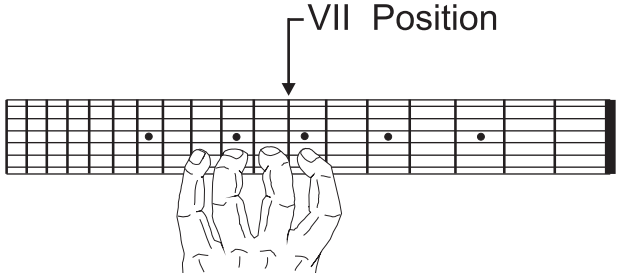
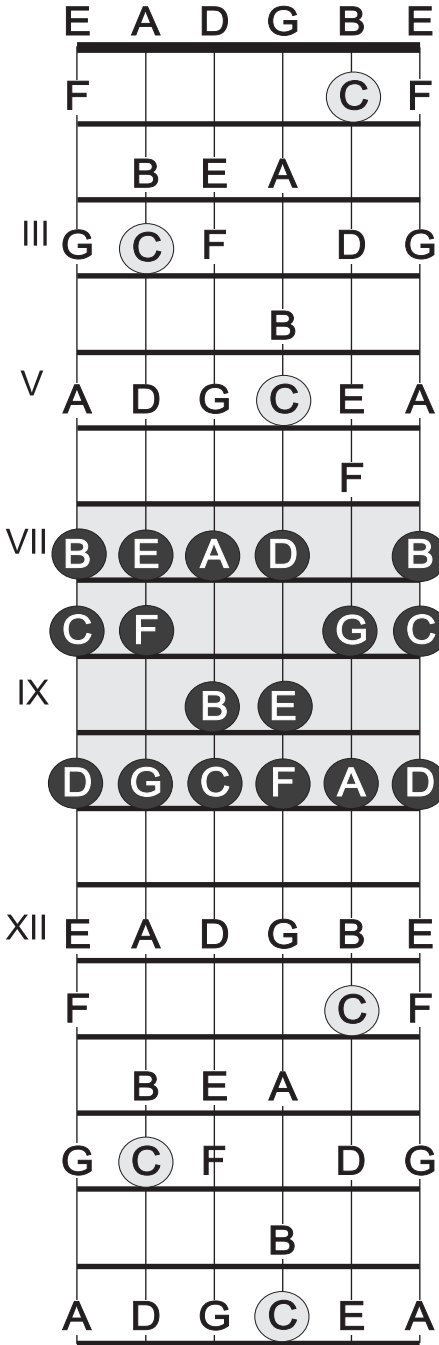

VII Position

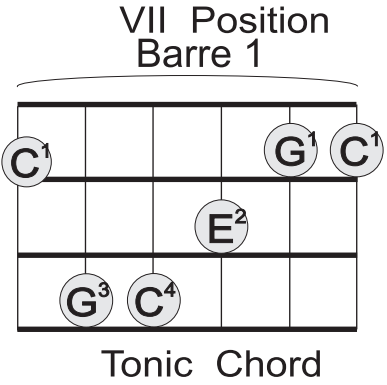
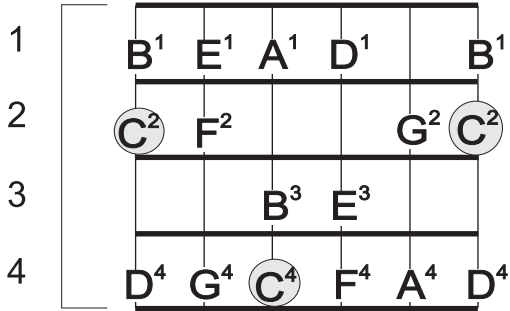

NOTE:

This position has no shifts or stretches. All notes will fall under the fingers. Follow the fingerings carefully and don't ignore your baby finger!

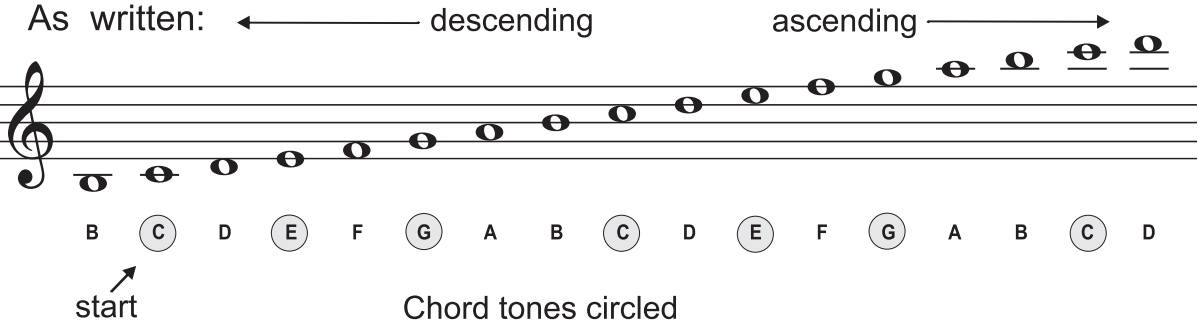

C MAJOR SCALE

IX POSITION

NOTE:

1. This scale fingering has two shifts. The first shift (ascending) is at string 2, fret X. The second shift (descending) is at string 5, fret X.
2. Remember to always play scales identically ascending and descending.
3. This scale form starts one octave higher than the previous forms.
4. See alternate scale fingerings on pg. 42

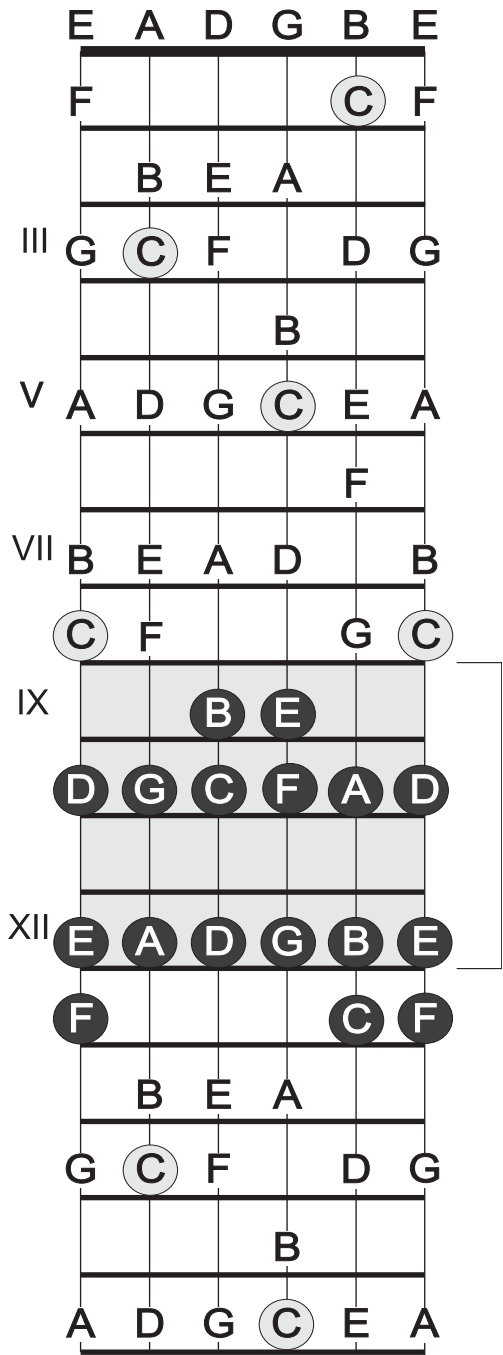

IX Position

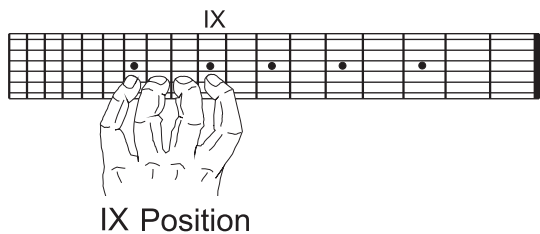
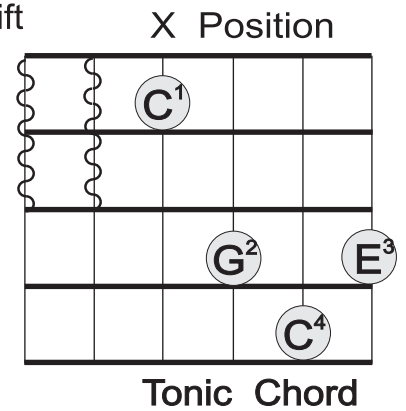
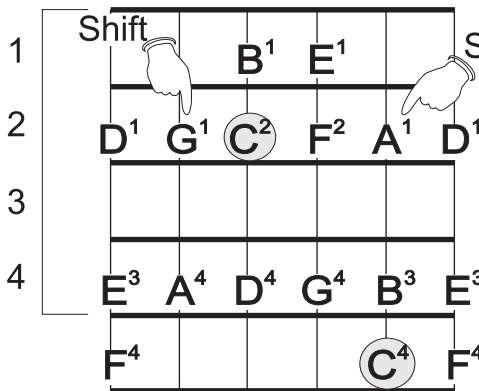

IX Position

As written:

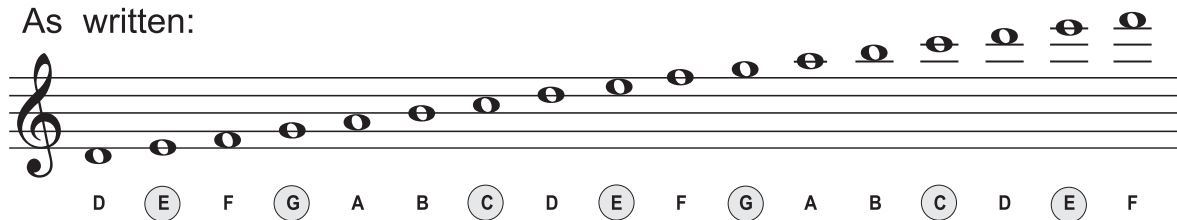

Chord tones circled

start

C MAJOR SCALE

XII POSITION

NOTE:

1. This position is a repeat of the open position, only one octave higher. Compare the two positions. From this point on, all the vertical scale forms repeat themselves, as if on a small fretboard beginning at fret XII.
2. Depending on the length of your fretboard, practice the scale forms covered thus far in these upper positions as well. Note that because of the spacing of the frets in these upper positions the technique is somewhat altered due to the smaller distances between frets.

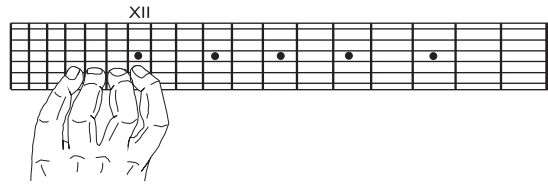
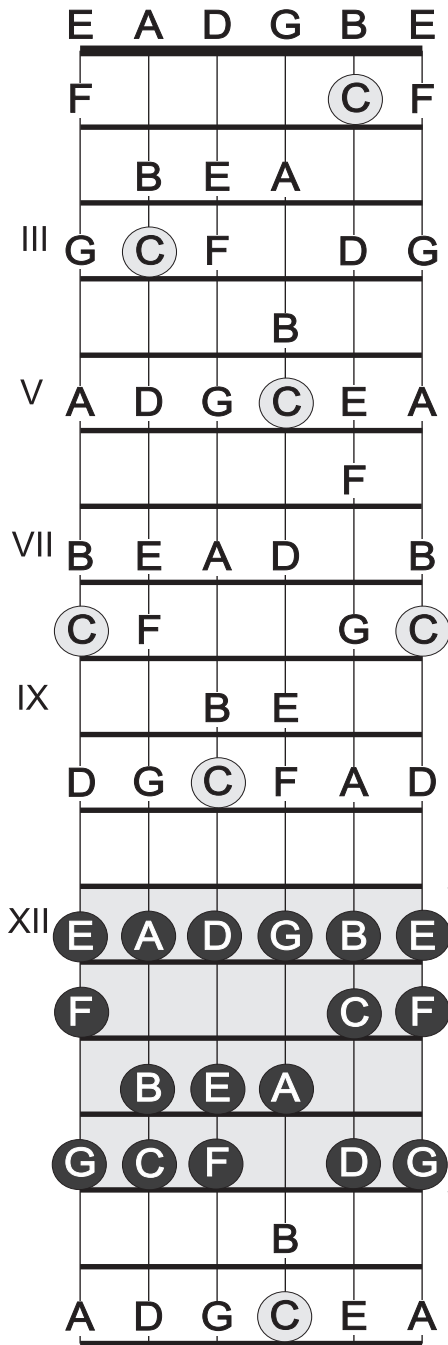

XII Position

XII Position

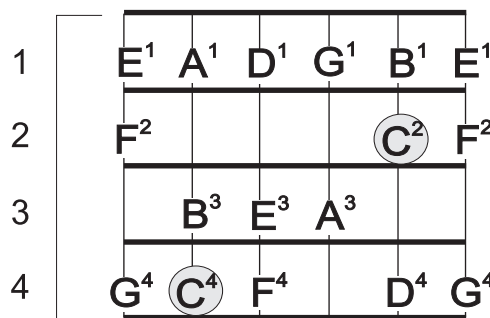

XII Position

1/2 Barre

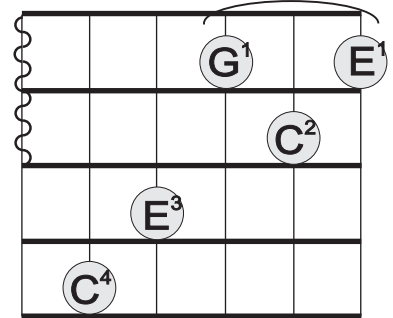

Tonic Chord

As written:

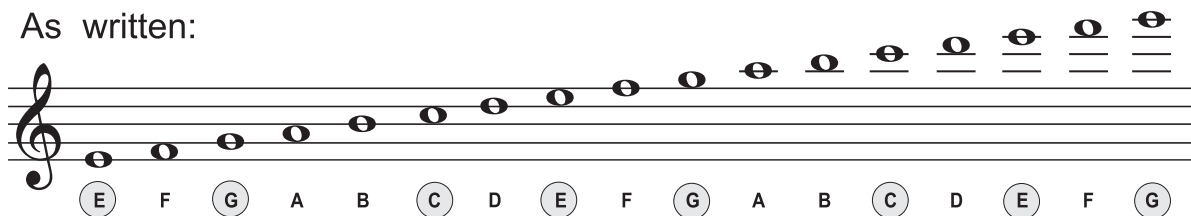

Chord tones circled

start

THE NATURAL MINOR SCALE

At this point you probably have a pretty good feel for the positions of the C major scale.

Let's move on to minor scales. Remember what we said about systems at the beginning in case you're wondering why we are moving to minor scales already. First, we will examine some "practical" theory.

Remember what was said about the major scale, it is a tone, tone, semi-tone, tone, tone, tone, semi-tone spacing of notes beginning at a root note.

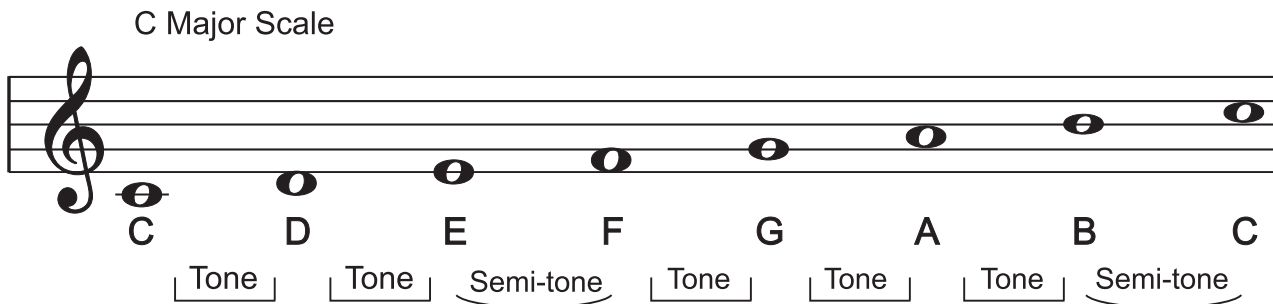

Now let's examine the natural minor scale.

The natural minor scale shares the same notes as the major scale. In other words, the notes of the C major scale share all the same notes as its "relative" minor scale, the A natural minor scale.

This is a very important point, and looking at it from the fretboard it means this: all the scale positions of C that you have been learning will remain exactly the same for A natural minor with one exception, the root note will now be A rather than C. The root note will be A in the key of A natural minor and in the key of C major it will be C.

The question then is: why is one scale minor and the other major if they both use the same notes? Let's examine that.

C MAJOR (C tonic) Key of C

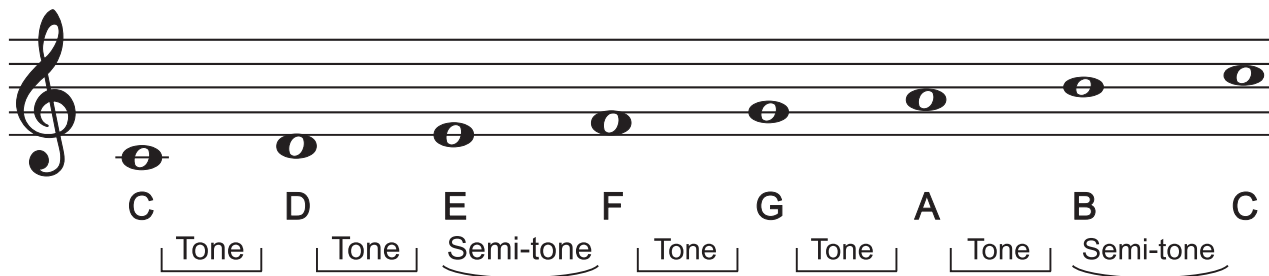

A NATURAL MINOR (A tonic) Key of A minor

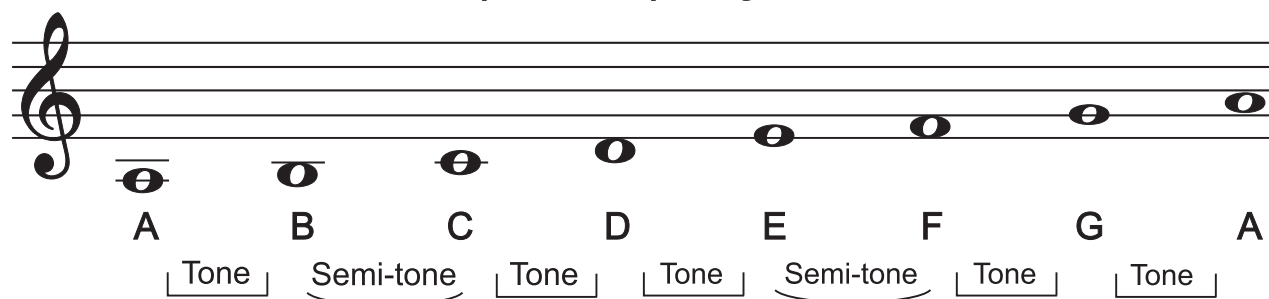

As you can see, even though the notes are the same, the "spacing" of the tones and semi-tones in the minor scale is different from the spacing in the major scale because the tonal centre has changed, consequently, so has the key.

MAJOR SCALE

Tone Tone Semi-tone Tone Tone Tone Semi-tone

NATURAL MINOR SCALE

Tone Semi-tone Tone Tone Semi-tone Tone Tone

It is the spacing between the notes and their relationship to the tonic that give the scale its quality, not the notes individually.

The A natural minor scale is called the relative minor of C major because it shares the same notes as the C major scale.

The tonal centre of C major is C, the tonal centre of A minor is A. The C major scale is in the "key" of C, the A minor scale is in the "key" of A minor.

THE RELATIVE MINOR

In order to arrive at the root of the relative minor of any major key count up six scale degrees from the root of the major scale.



or count back three for the same result.

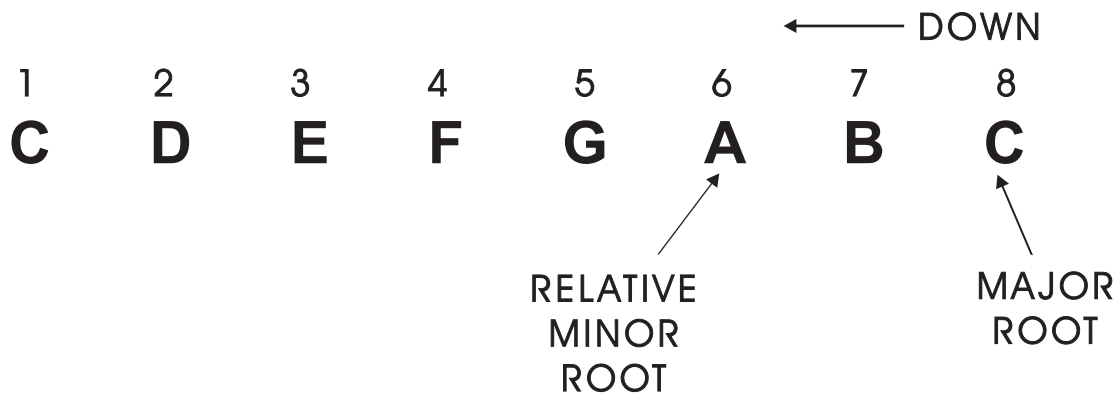

Guitaristically speaking, this means that by learning the major scale fingerings you have in effect learned the natural minors as well. The only difference being that the *tonal centre has changed. However, each of the minor scales must still be practiced individually and heard as a new sound.

With that new knowledge, let's move on.

*root note

QUESTIONS 2

1. Why does a major scale sound different than a minor scale?

2. Describe in your own words the difference in "sound" between major and minor _____
3. Would you call a major scale a bright sound or a dark sound? _____
4. Is the song Twinkle Twinkle Little Star in a major or minor key? _____
Greensleeves? _____ Home on the Range? _____ Scarborough Fair? _____
5. What is the tonic of A minor? _____
6. What is the order of tones and semi-tones in a natural minor scale?

7. Why are A minor and C major called "relative?" _____

8. Where does the first semi-tone fall in a major scale? _____
9. Where does the first semi-tone fall in a minor scale? _____
10. What is the relative major of A minor? _____
What is the relative major of D minor? _____
What is the relative major of E minor? _____
What is the relative minor of G major? _____
What is the relative minor of C major? _____
What is the relative minor of F major? _____
11. Titles in Classical music often designate the keys of pieces, such as "Symphony in E minor," or "Sonata in D Major." Listen to some music in different styles and qualify whether they are major or minor.

A NATURAL MINOR SCALE

I POSITION

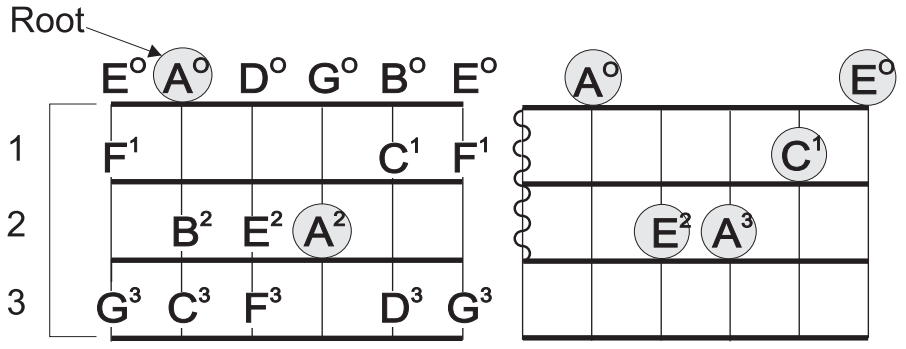
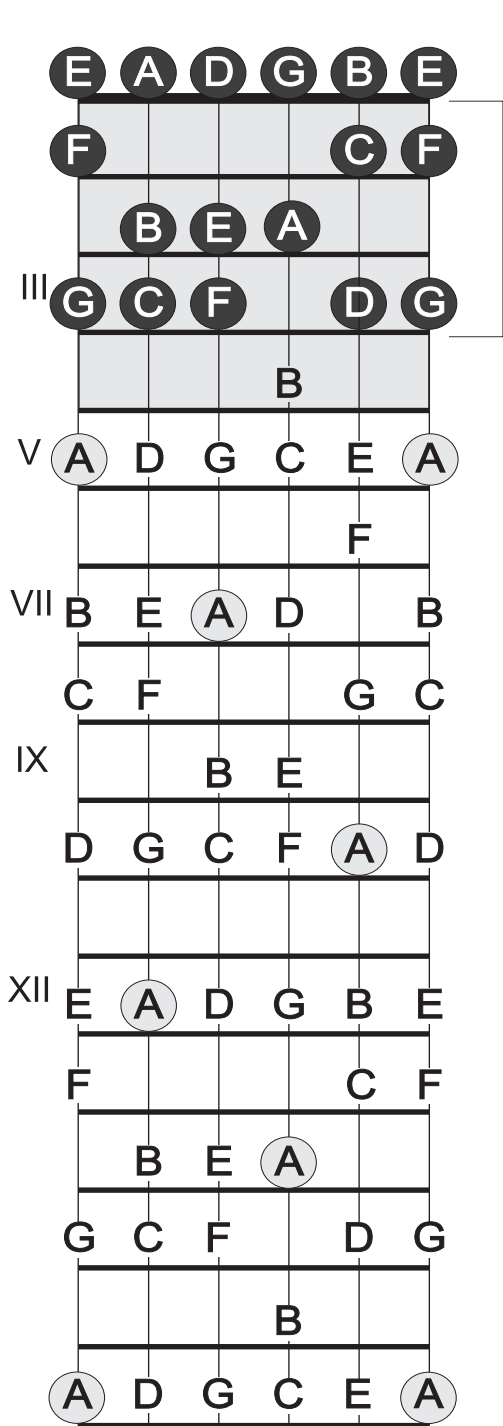

Tonic Chord

NOTE:

Start at open A, string (5). Play all the notes in position and return to the root note. Listen to the 'sound' of the scale and be able to identify it by ear.

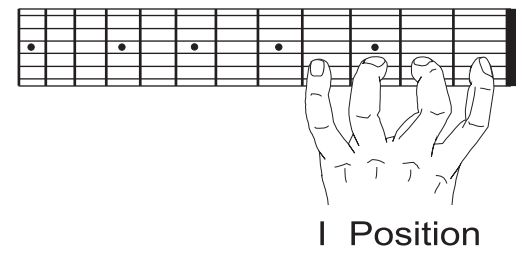

As written:

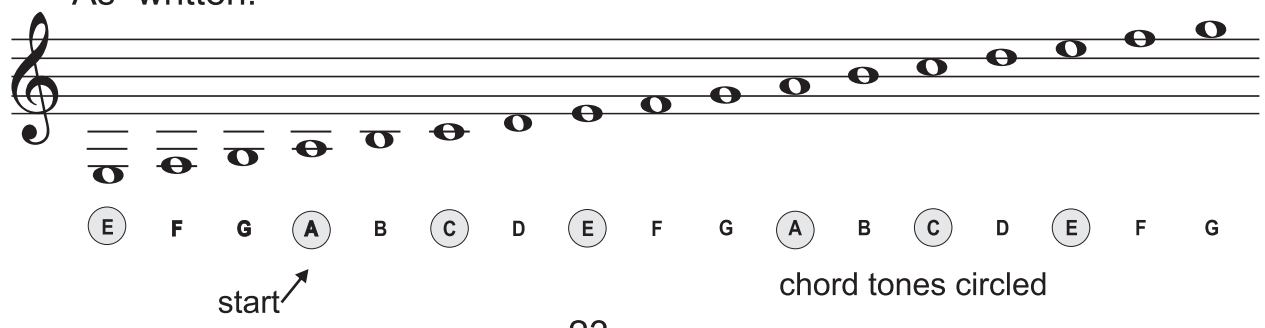

A NATURAL MINOR SCALE

II POSITION

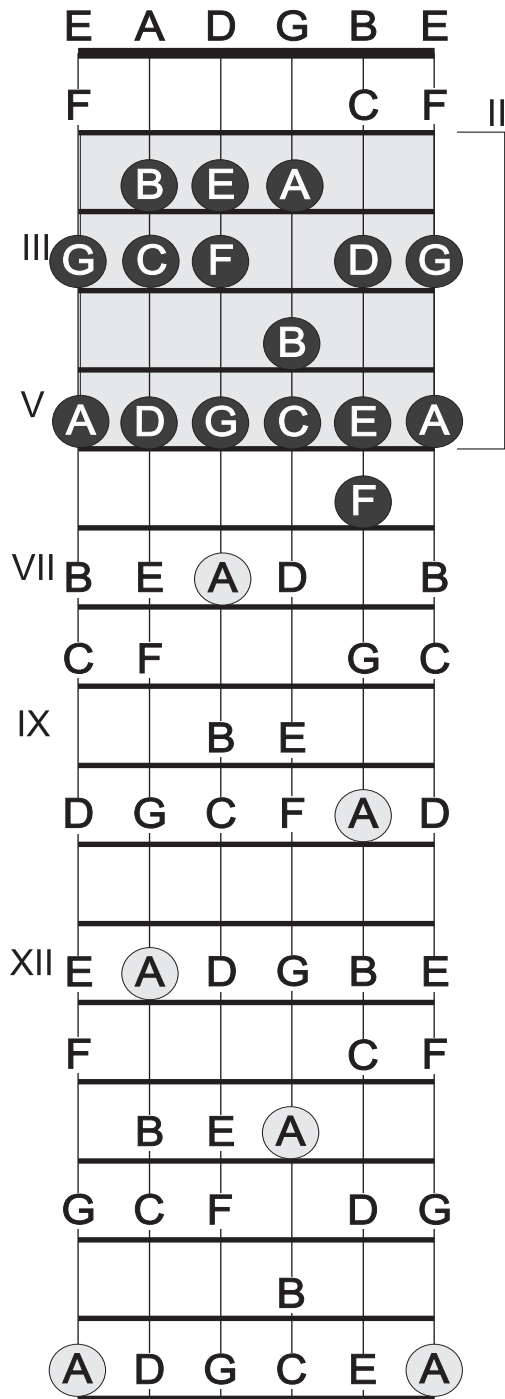

As written:

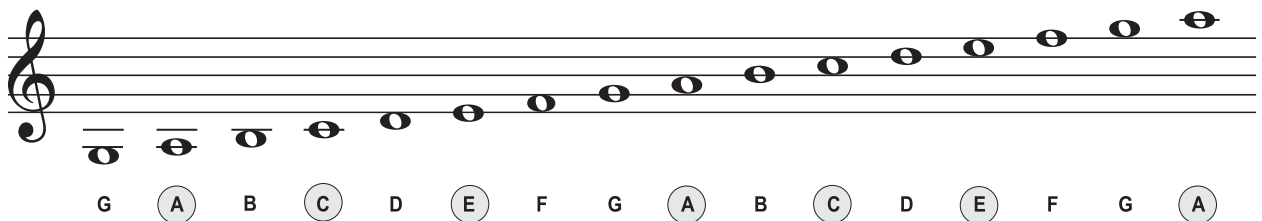

start

chord tones circled

II Position

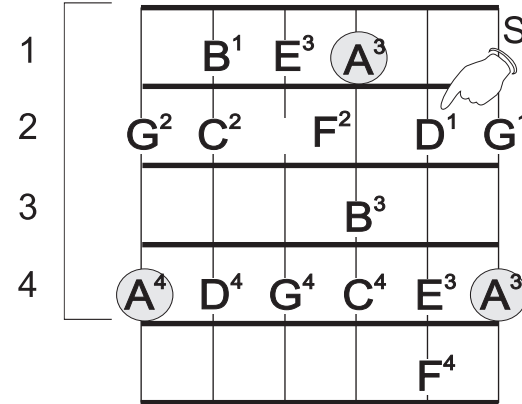

Shift

II Position

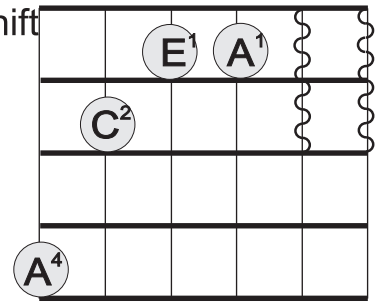

Tonic Chord

NOTE:

1. No open strings, shift at string ② to position III. Start on A and play the low G when descending, then return to root.
2. If fingering some of these chord forms is difficult, don't worry about it and move on; as your hands get stronger and dexterity increases these forms will come.

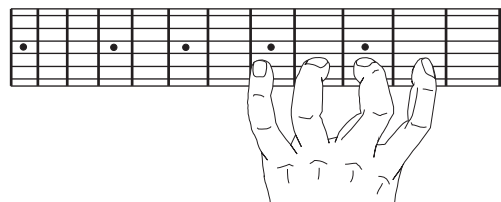

II Position

A NATURAL MINOR SCALE

V POSITION

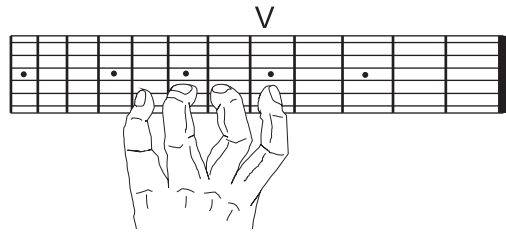
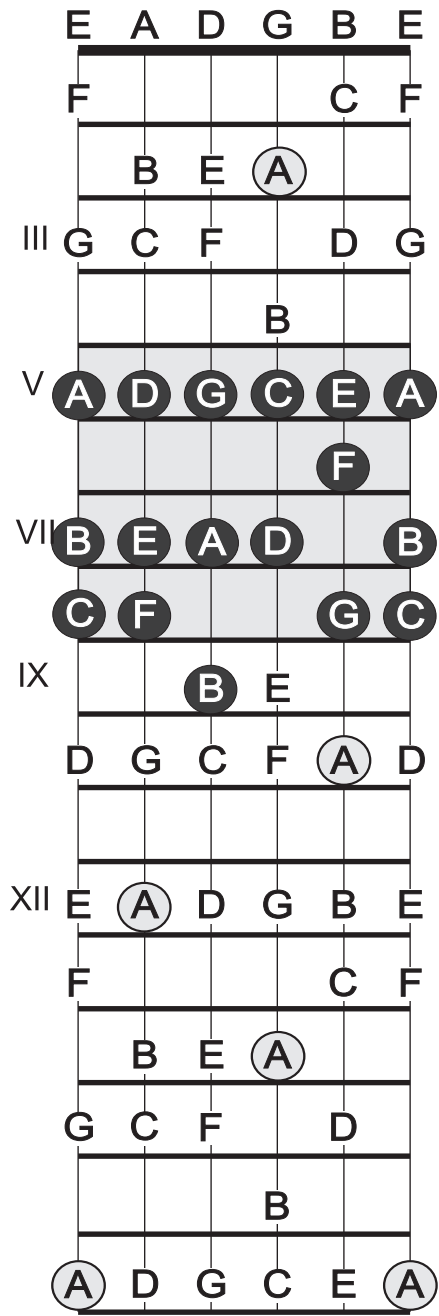

V Position

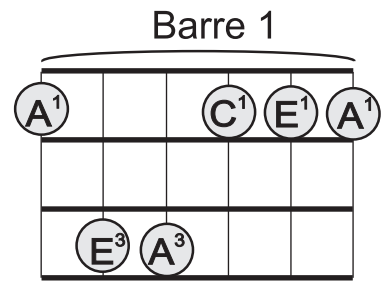
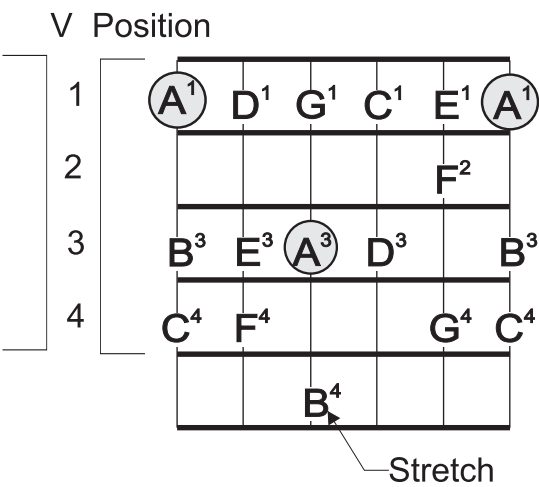

Tonic Chord

Barre 6 strings with finger 1

Barre chords can be difficult. Keep finger 1 straight and round your other fingers.

NOTE:

1. Stretch at ④ string to B with finger 4. Stretch, don't jump.
2. Be able to identify the "sound" of the scale you are playing, i.e. minor or major.

As written:

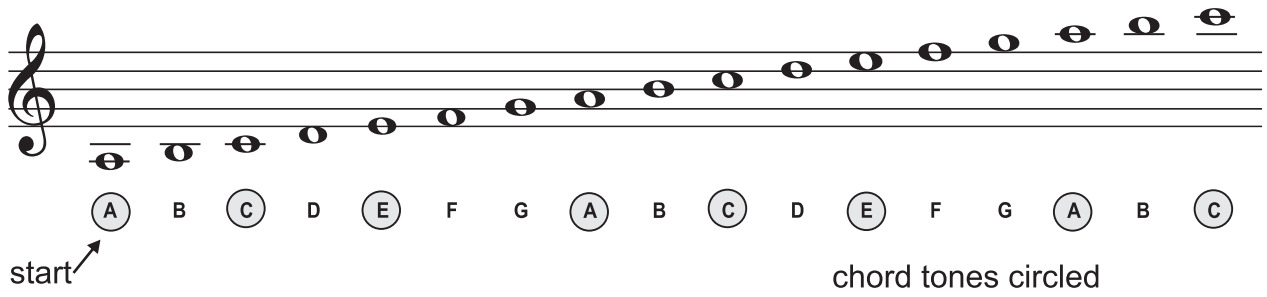

A NATURAL MINOR SCALE

VII POSITION

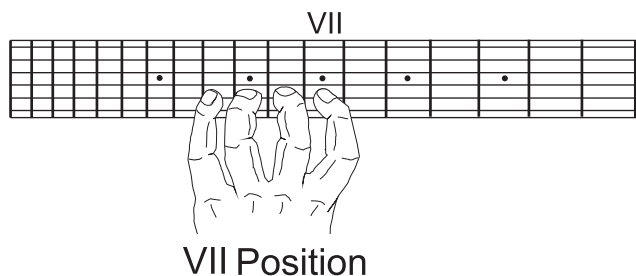
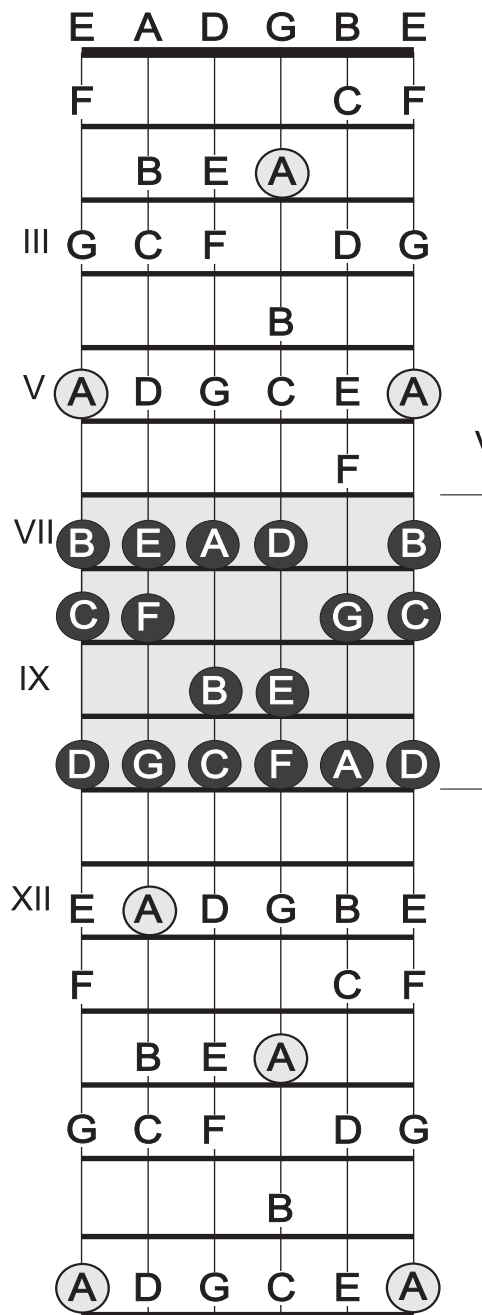

VII Position

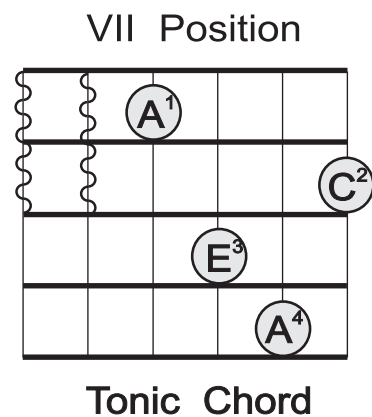
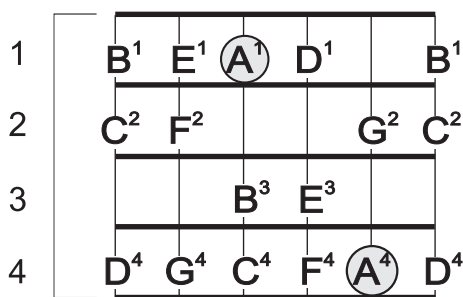

Tonic Chord

NOTE:

No shifts, no stretches.
Remember to always start on the root.

As written:

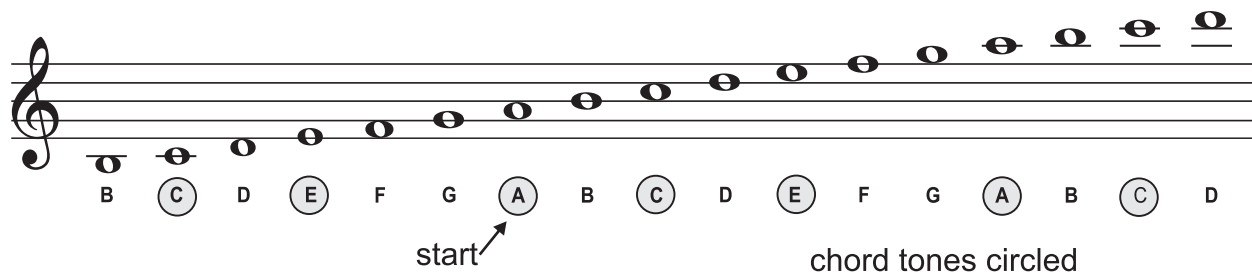

A NATURAL MINOR SCALE

IX POSITION

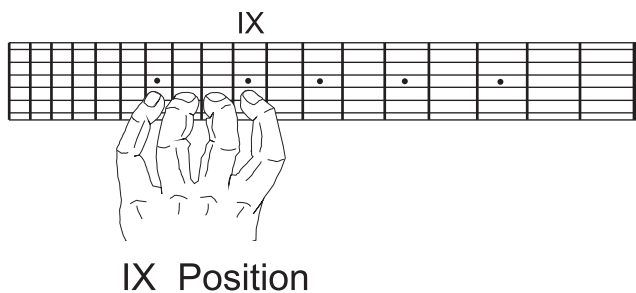
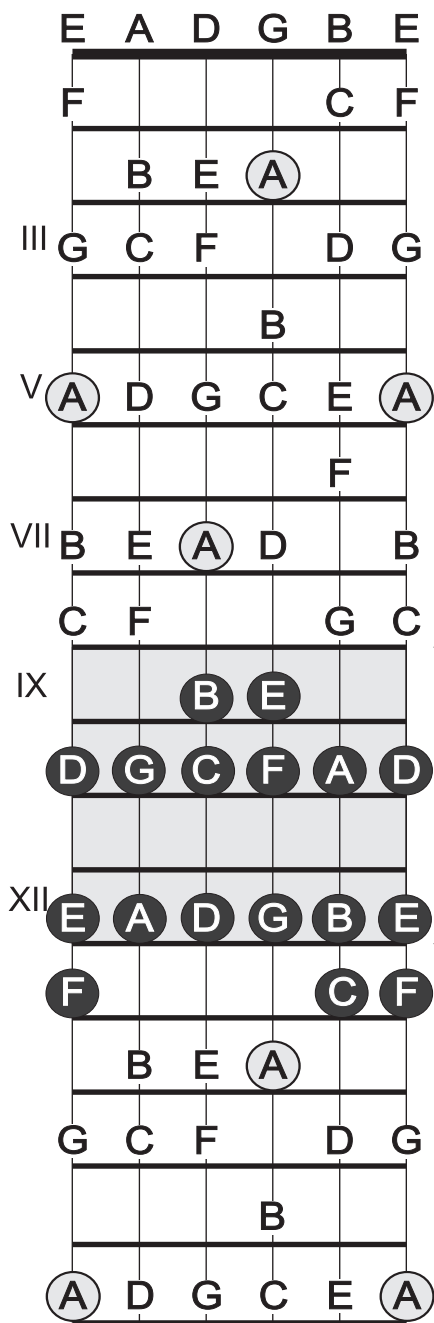

IX Position

- 1
- 2
- 3
- 4

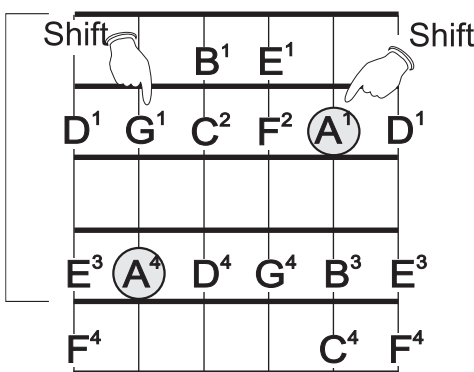

IX Position

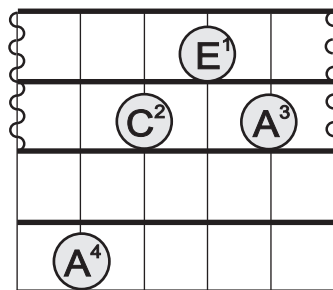

Tonic Chord

NOTE:

There are two position shifts in this scale form. Follow the fingering carefully.

As written:

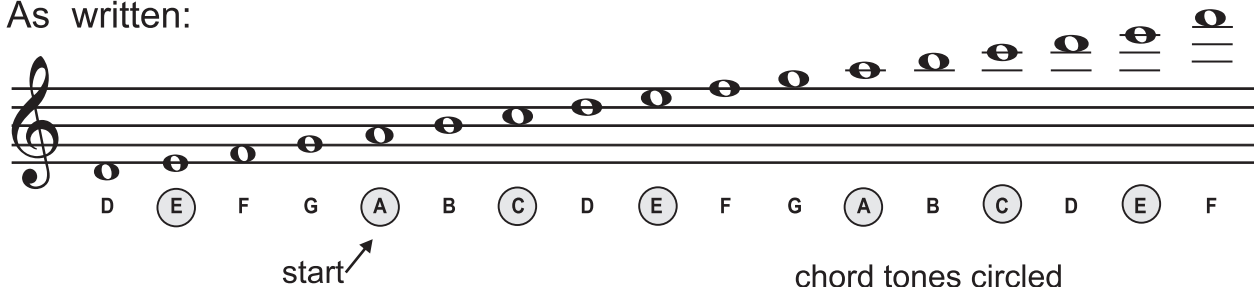

A NATURAL MINOR SCALE

XII POSITION

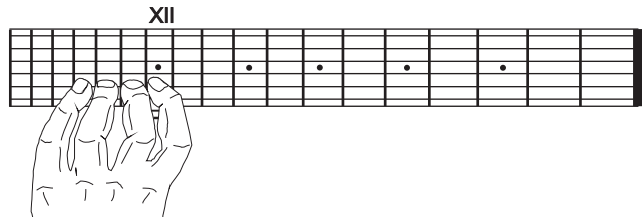
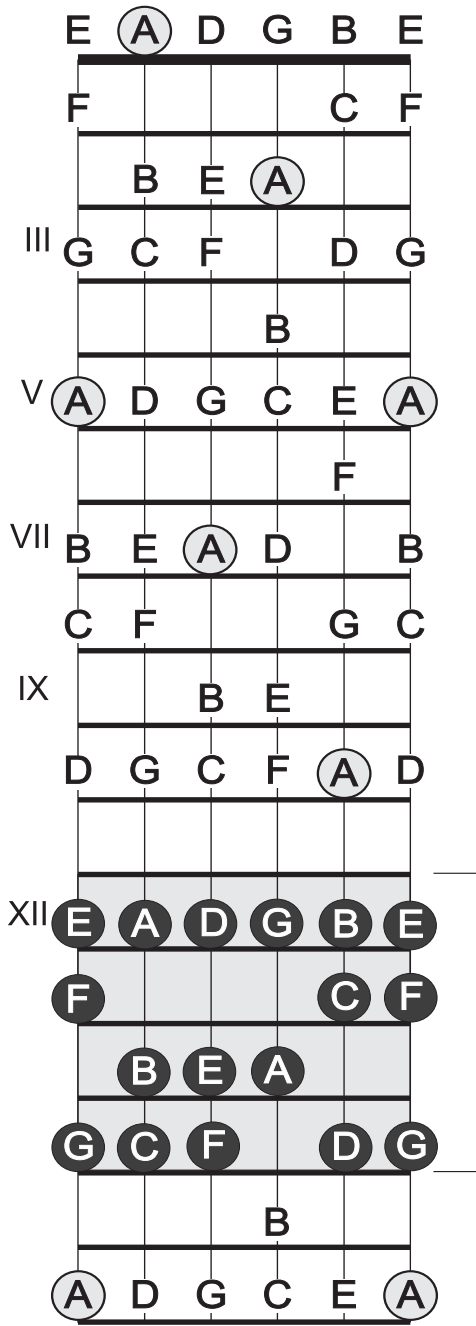

XII Position

NOTE:

Think of fret XII as the beginning of another short neck. All scale forms begin to repeat at fret XII, one octave higher. Compare the scale form at fret I to fret XII.

XII Position

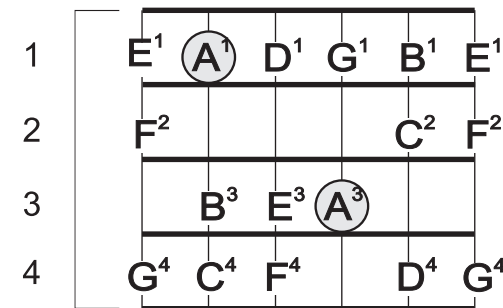

XII Position
Barre 1

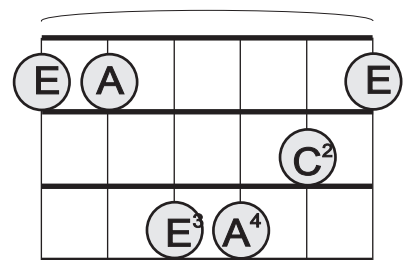

Tonic Chord

Repeat of 1st position chord one octave higher

Note:

In a barre chord form, finger 1 covers all six strings as a capo would.

As written:

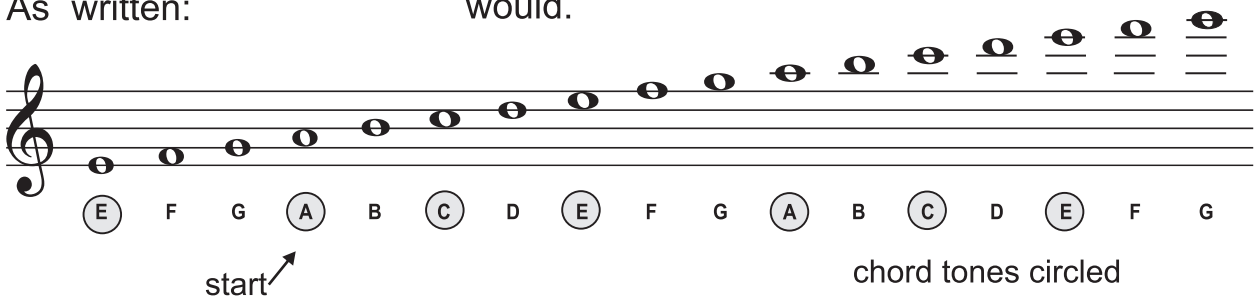

THE MAJOR PENTATONIC SCALE

The pentatonic scale is probably the most common scale used by guitar players for soloing in all the pop genres. It is often used for melody writing as well because of its striking simplicity. Before we explore the pentatonic scale on the fretboard, let's once again look at some "practical" theory.

The pentatonic scale is a five-note scale. It does not have any semi-tones. A major pentatonic scale can be arrived at by starting with a major scale and then eliminating the IV and VII degrees of the scale or in other words, by removing the semi-tones. The major pentatonic scale still sounds major because of the major 3rd distance between the 1st and 3rd notes of the scale. The distance of a tone plus a tone is a major 3rd.

The Major Scale Notes.

do re me fa so la ti do
C D E F G A B C
major 3rd
tone tone

The Major Pentatonic Scale Notes.

C D E G A C
major 3rd
tone tone

This is a five-note scale with no semi-tones. If you listen to music in any style, you have heard this scale sound many times.

C MAJOR PENTATONIC SCALE

I POSITION

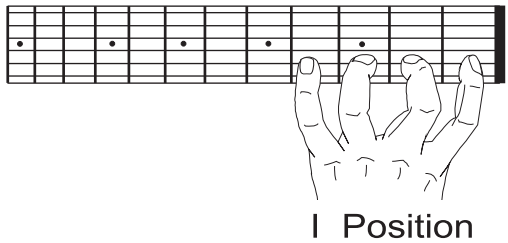
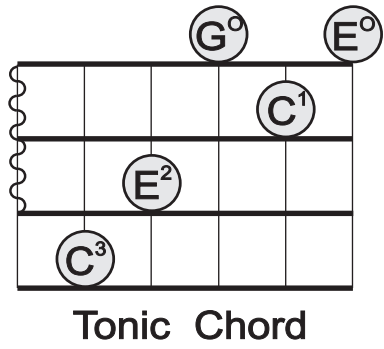
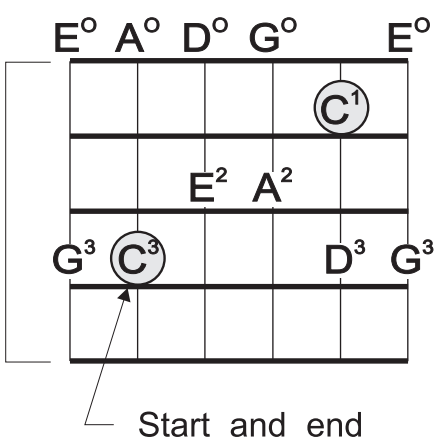
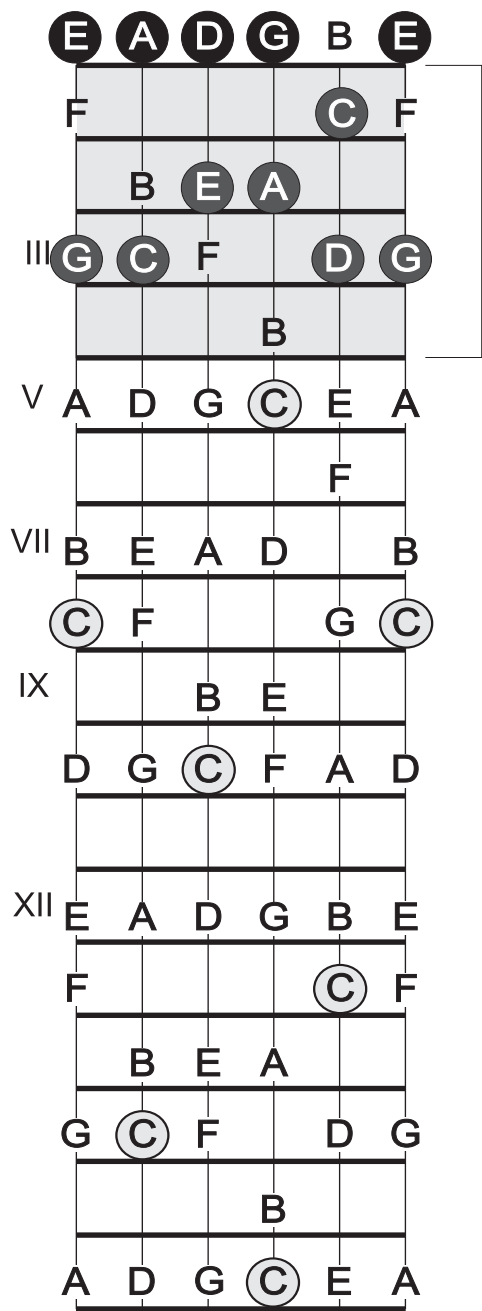

NOTE:
Once again, practice each position carefully with repetitions. Listen to the sound of the scale and be able to identify it by its sound.

As written:

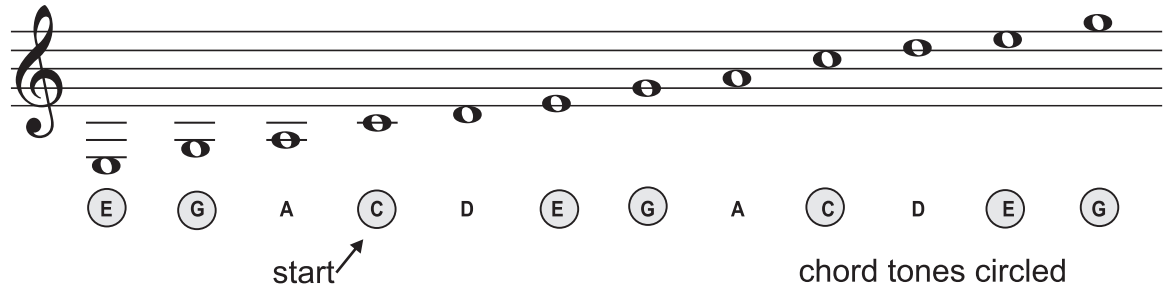

C MAJOR PENTATONIC SCALE

II POSITION

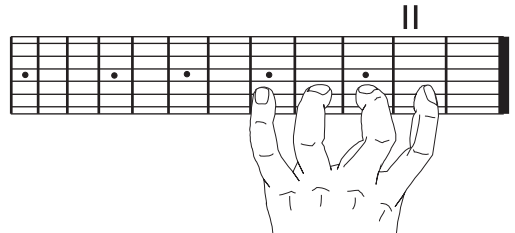
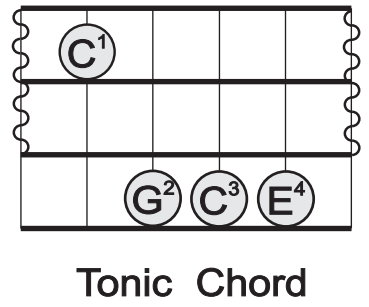
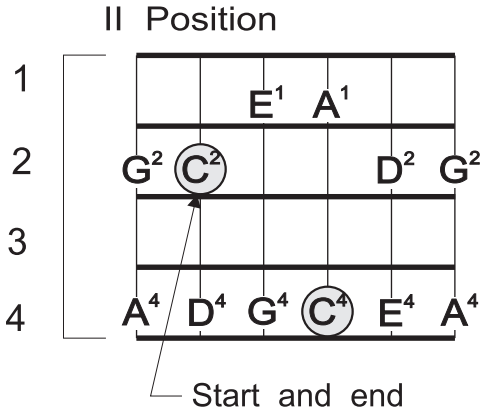
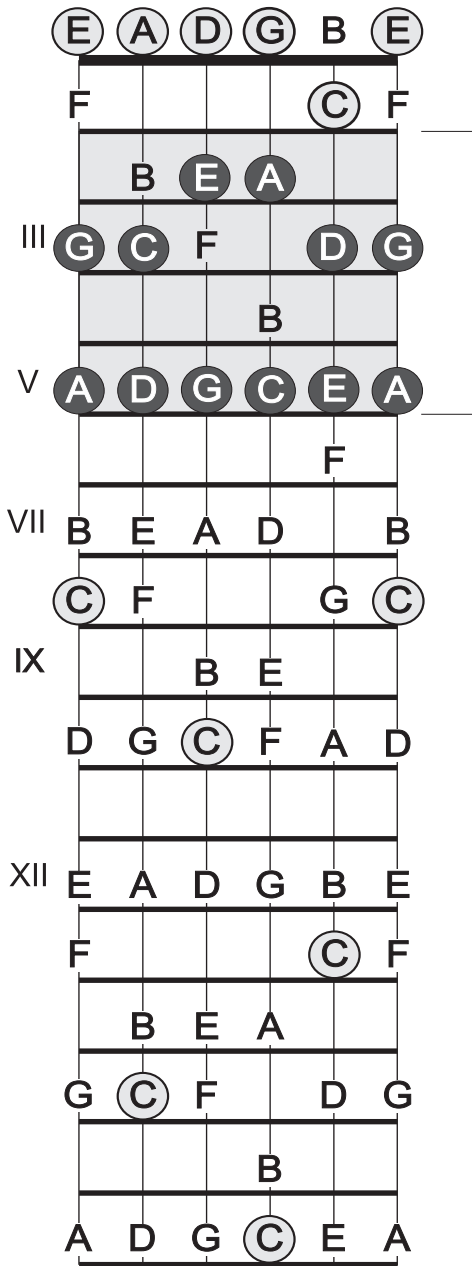

NOTE:

1. Starts 3rd fret, therefore, finger 3. Play the notes in position in their order.
2. Repeat this process 10-20 times. Remember, one finger for each fret.
3. Don't forget to follow position fingerings. The above would be starting from C, i.e. 2-4, 1-4, 1-4, 2-4, 2-4, etc.

As written:

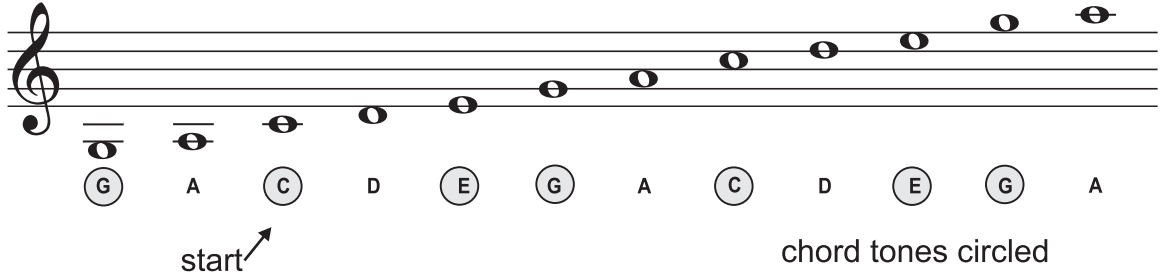

C MAJOR PENTATONIC SCALE

V POSITION

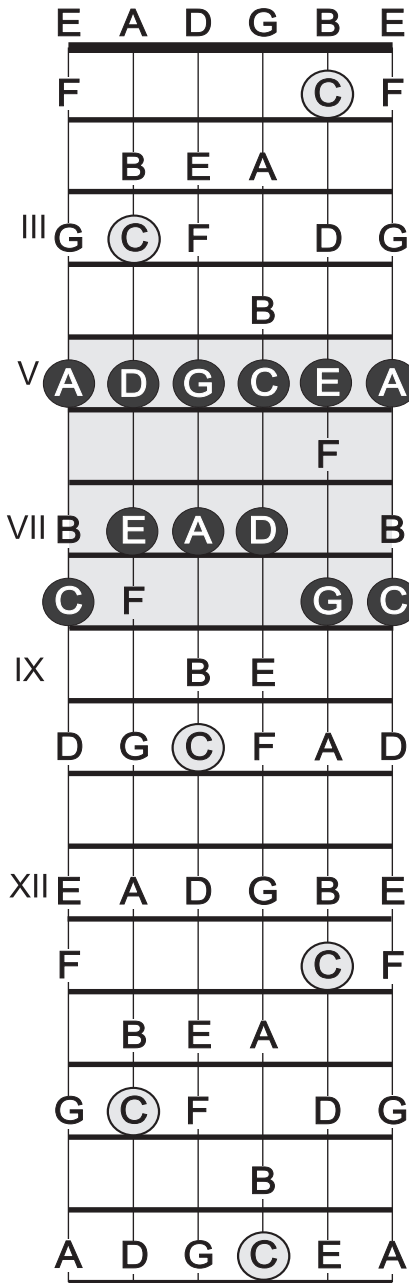

V Position

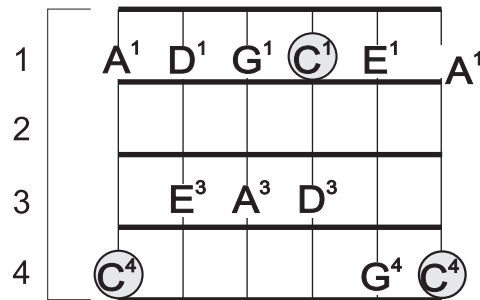

V Position Barre 1

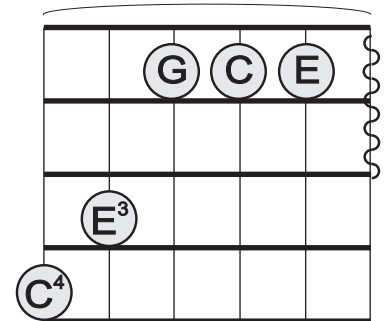

Tonic Chord

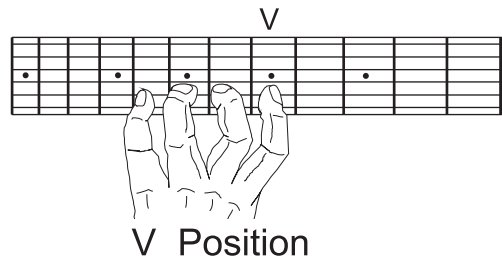

V Position

NOTE:

This is probably the most used guitar scale form.

As written:

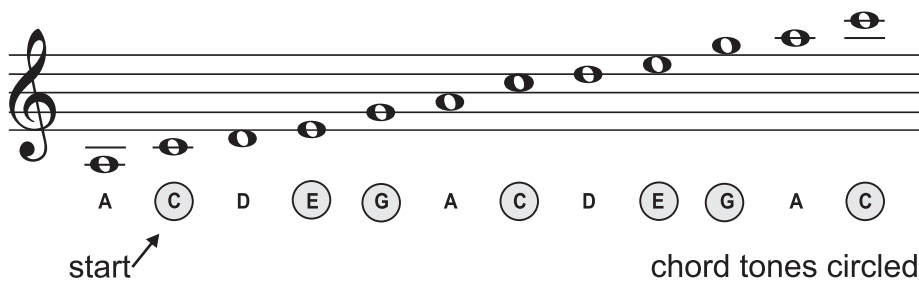

C MAJOR PENTATONIC SCALE

VII POSITION

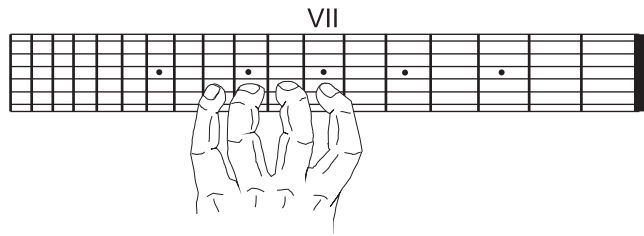
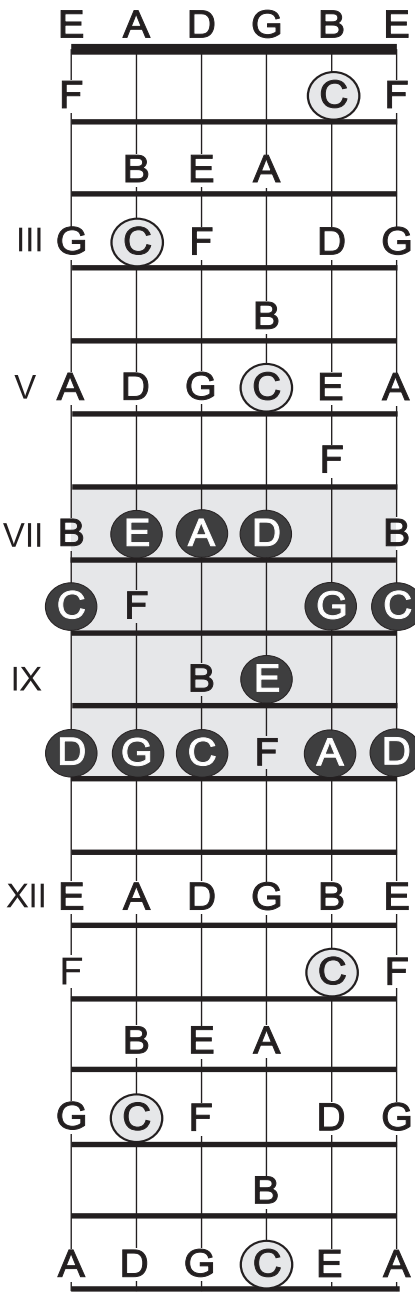

VII Position

VII Position

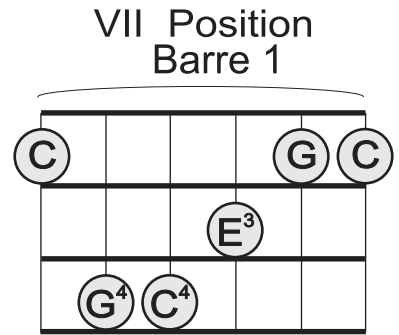
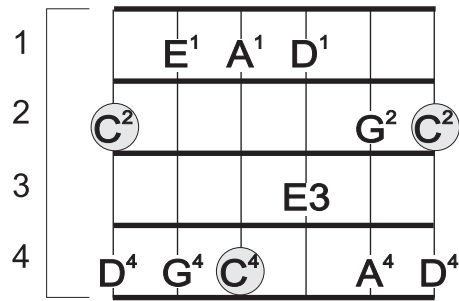

Tonic Chord

NOTE:
Follow fingerings.

As written:

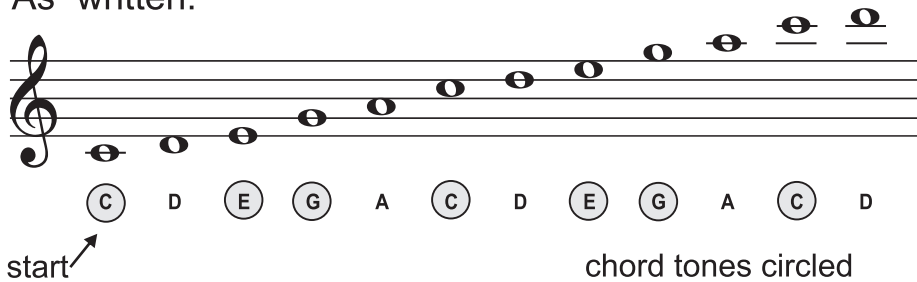

C MAJOR PENTATONIC SCALE

IX POSITION

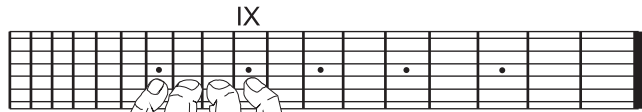
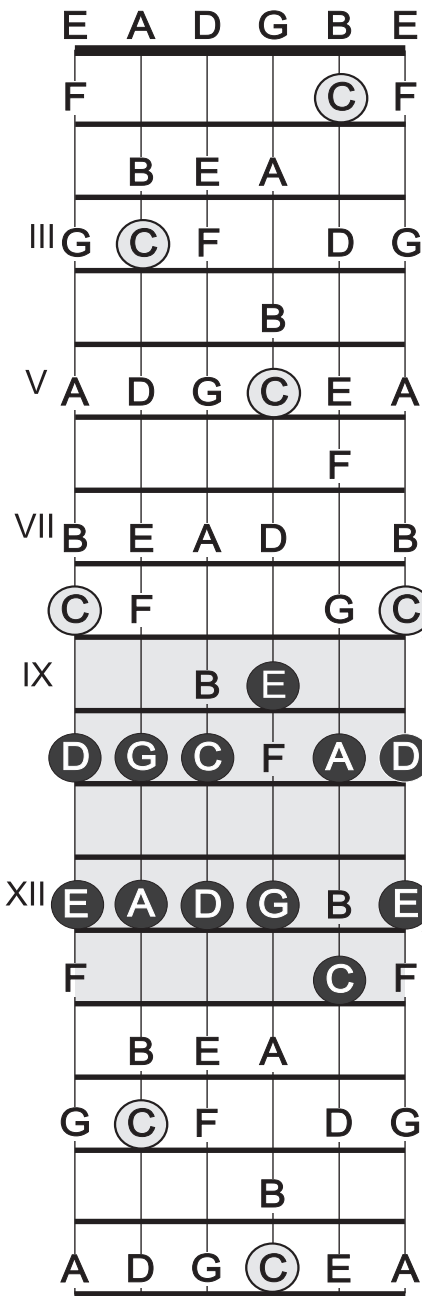

IX Position

IX Position

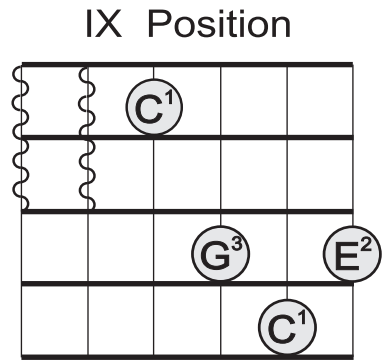
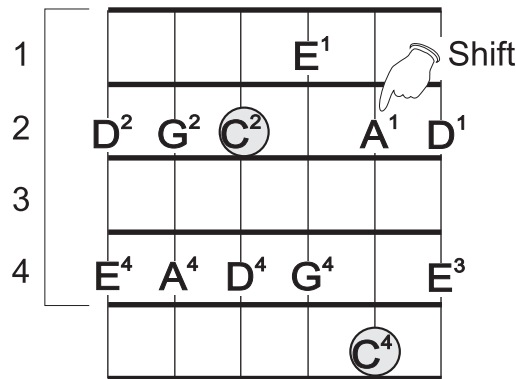

Tonic Chord

NOTE:

Watch for shift at position X.
 Start at C on string ④.
 Fingering is 2-4, 1-4, shift
 1-4, 1-3, then descend.

As written:

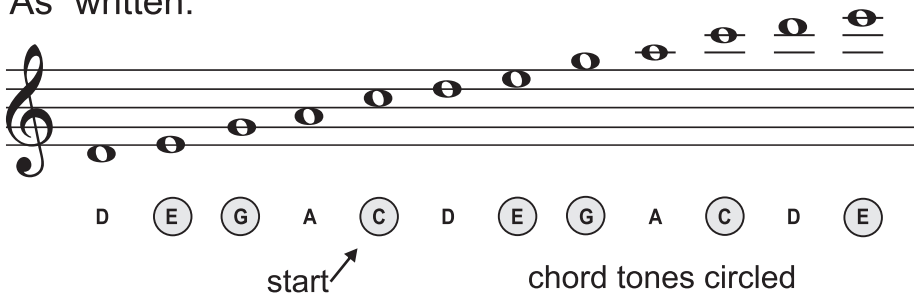

C MAJOR PENTATONIC SCALE

XII POSITION

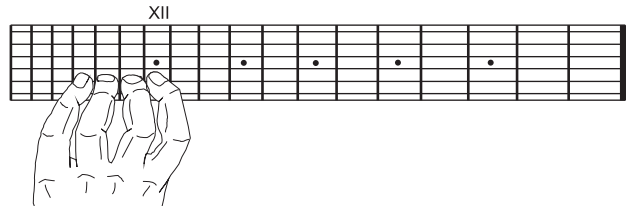
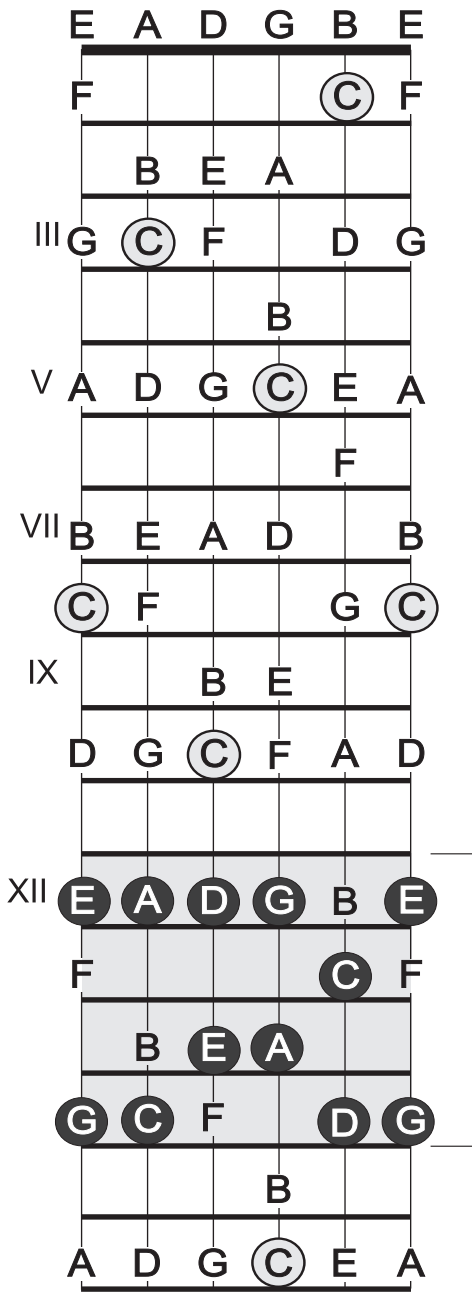

XII Position

NOTE:

Fingering starts at C, 4, 1-3, 1-3, 2-4, 1-4, then descend.

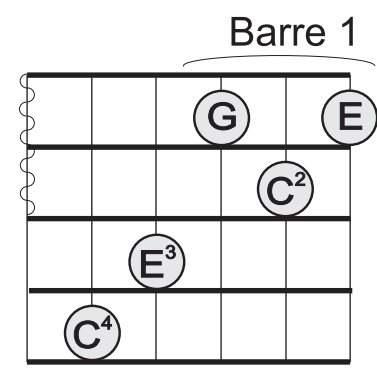
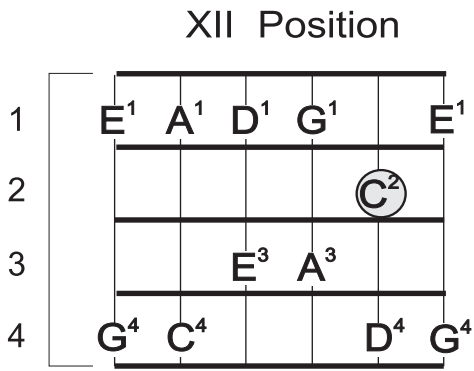

Tonic Chord

As written:

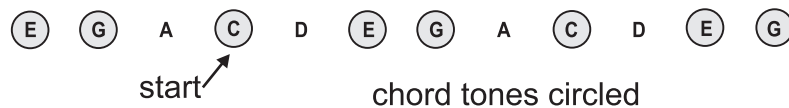
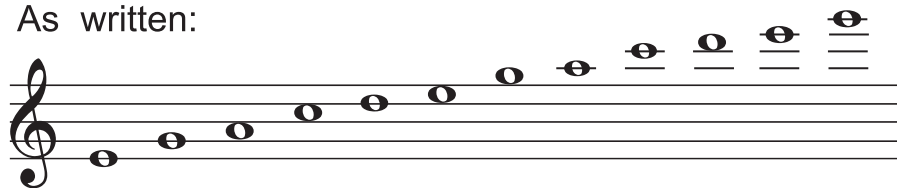

QUESTIONS 3

1. How many notes in a pentatonic scale? _____
2. What scale degrees are eliminated in a major scale to make a pentatonic scale?

3. Where are the semi-tones in a pentatonic scale? _____

4. How many frets is the distance of a minor third? _____
5. How many frets is the distance of a major 3rd? _____
6. Are pentatonic scales common in rock music? _____
7. Can you think of a guitar solo that uses the pentatonic scale?
8. What is an advantage to using a pentatonic scale in a solo situation over a major or minor scale?

9. Why does the major pentatonic scale have a major sound even though two notes have been removed from the major scale?

- 10 Name the notes of the following scales:
C Major pentatonic scale _____
G Major pentatonic scale _____
D Major pentatonic scale _____
A Major pentatonic scale _____
E Major pentatonic scale _____

THE MINOR PENTATONIC SCALE

The pentatonic scale we covered in the previous pages was the C major pentatonic. The tonal centre is C. In order to change the C major pentatonic scale to an A minor pentatonic scale, the "tonal centre" is changed to A.

Practice each of the previous scales of C major pentatonic with A as the tonal centre, just the same way in which we changed the C major scale to A natural minor. Remember, C major is the key of C, whereas A minor is the key of A; A is the tonal centre.

Let's examine a chord progression - play and listen:

Key of C Major

||: C | Am | F | C :||

Key of A Minor

||: Am | Dm | Em | Am :||

This is an over-simplification, but it might make it easier to understand. Tonal centre is often a starting and ending point.

THE A MINOR PENTATONIC SCALE VERTICAL FORMS

I Pos.

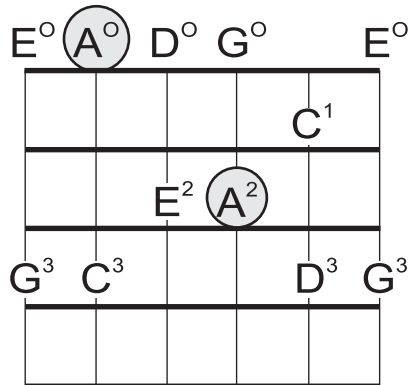

II Pos.

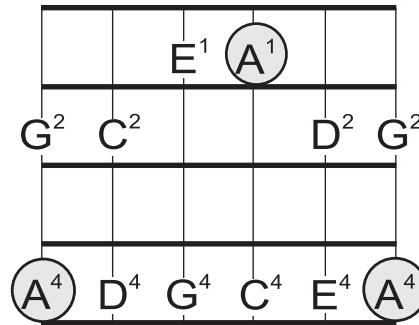

V Pos.

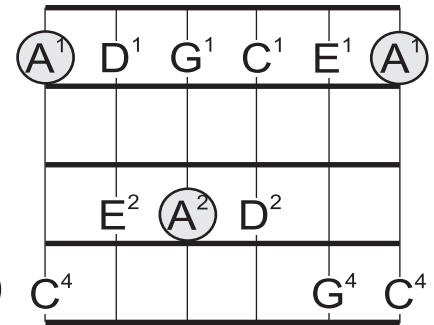

VII Pos.

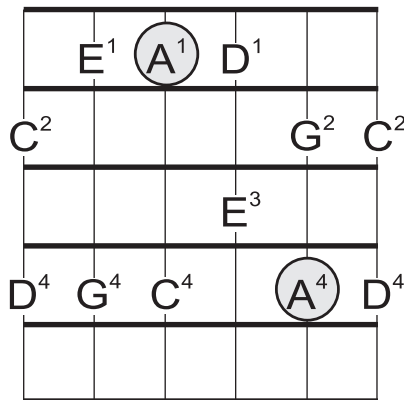

IX Pos.

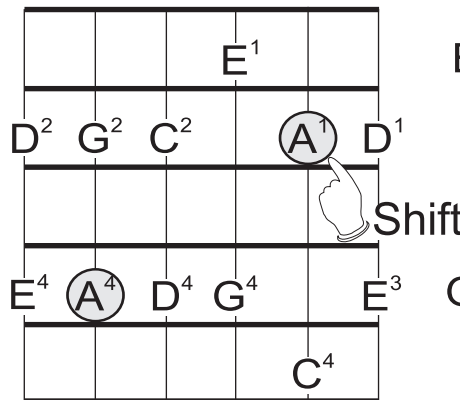

XII Pos.

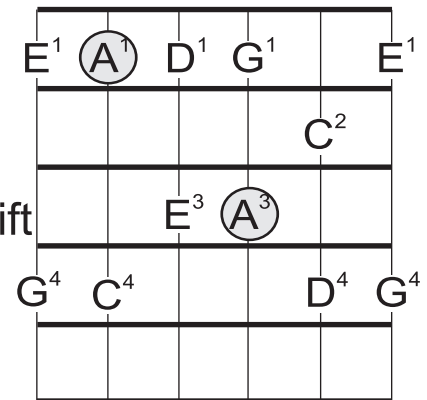

Play the above scale forms with special attention to starting on the A root. Listen to the sound of the scale.

The A minor pentatonic scale is often used in "the Blues." When it is played in a blues format the chords may look something like this:

Key of A

Count: 1 2 3 4 | 1 2 3 4 | 1 2 3 4 | 1 2 3 4 |

2 | D7 / / / | D7 / / / | A7 / / / | A7 / / / |

3 | E7 / / / | D7 / / / | A7 / / / | E7 / / / :||

Repeat

This is a basic 12-bar blues, but as you can see, there are no minor chords and yet we are playing a minor pentatonic. Suffice to say for now, it works because it's the blues! This same idea applies in rock-type progressions.

4 | A 5*/ / / | C 5 / / / | D5 / / / | A 5 / / / :||

*refer to chord diagrams page 40 for explanation of this chord spelling.

Try the A minor pentatonic scale over powerchord-type progressions in the key of A and listen to the "sound." One thing to remember is that it is a five-note scale. Because of this, its applications are increased (not so many notes to conflict with notes in the chords). There are other reasons which go beyond the scope of this present study.

On the next page are some typical chord progressions in the keys of C major and its relative minor, A minor.

Record the chord progressions and practice your scales along with the recording. Make each progression at least two to four minutes in length. All the progressions will be written in 4/4 time, four beats per bar.

Here are chord diagrams for all the chords to be used in the given progressions.

CHORD DIAGRAMS

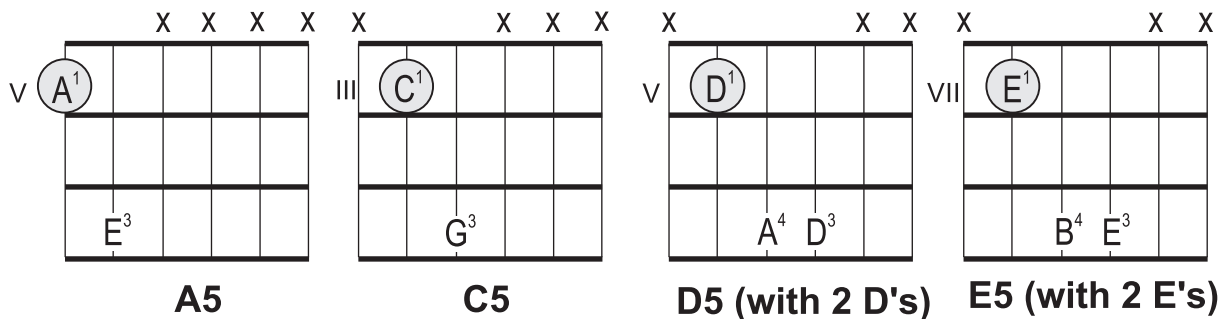
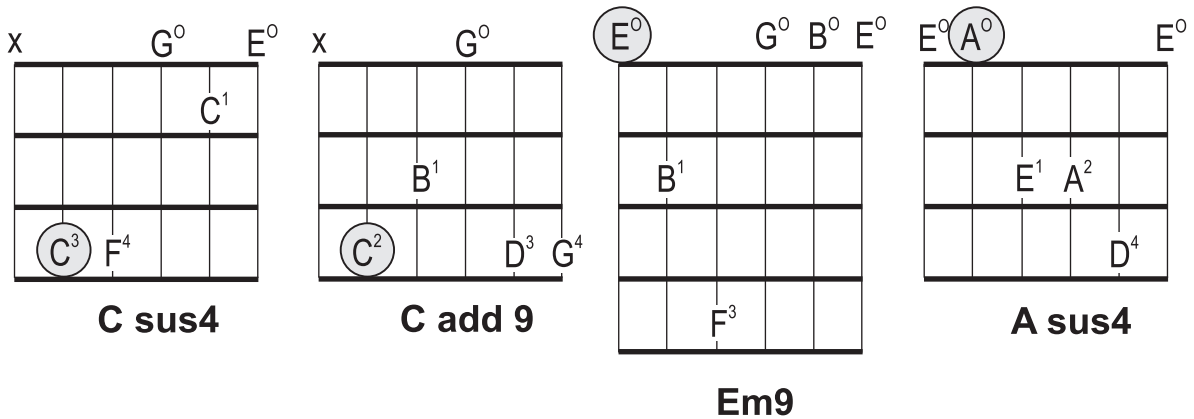
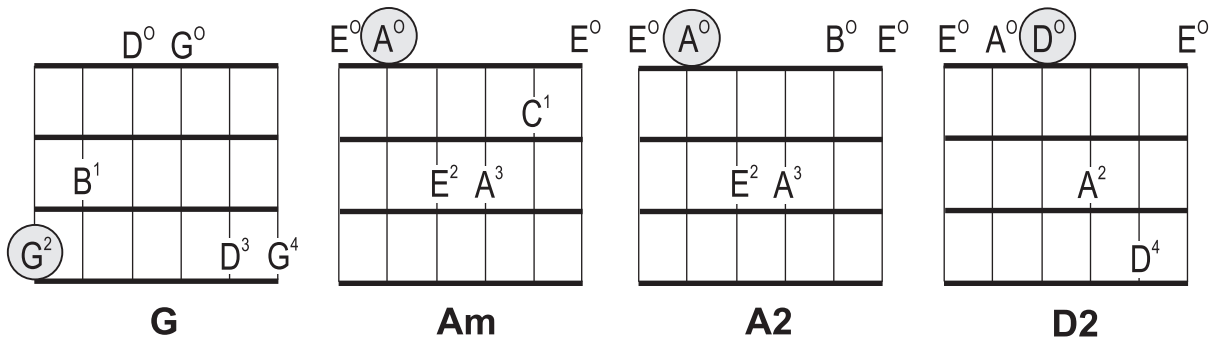
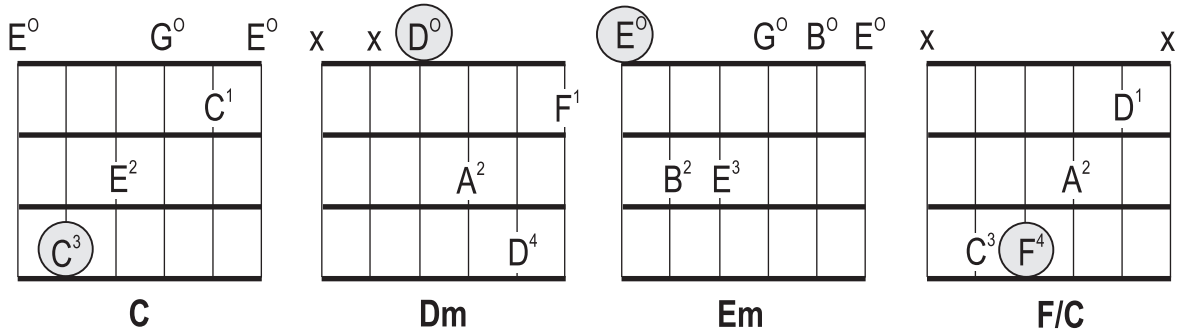

m = minor
 F/C = means F with C bass
 x = don't strike that string
 o = open string

"5" refers to a two-note chord, or power chord. It consists of an interval distance of a 5th between the two notes.

CHORD PROGRESSIONS

Record yourself playing these progressions and play over top with suggested scales.
Another option is to use pre-recorded playalongs at MyGuitarPal.com

Key of A minor - use A minor pentatonic

	: Am ///	Am ///	Am ///	Am ///
Dm ///	Dm ///	Am ///	Am ///	
Em ///	Dm ///	Am ///	Em /// :	

Key of C major - use C major or C pentatonic

||: C / C^{SUS4} / | C / / / | F / / / | F / / / |
| C / C^{SUS4} / | C / / / | G / / / | G / / / :||

Key of A - use pentatonic or natural minor

||: A² / / / | A² / / / | C² / / / | C / / / |
| D² / / / | D² / / / | Em / / / | Em / / / :||

Key of C - use C Major or C major pentatonic

||: C / / / | Am / / / | Dm / / / | G / / / :||

Tonal center A - A Natural minor/A Minor Pentatonic

||: A5 / / / | C5 / / / | G5 / / / | A5 / / / :||

A Natural minor/A minor Pentatonic

||: Am / / / | G / / / | F / / / | Em / / / :||

Tonal Center D - still uses only notes of C major/pentatonic

||: Dm / / / | /.* | C² / / / | C / / / |
| Dm / / / | /. | Em / / / | Em / / / :||

* /. means repeat previous measure

Tonal Center E - same notes as above C major/pentatonic

||: Em / / / | F / / / | G / / / | F / / / :||
||: C² / / / | D² / / / | F / / / | G / / / :||

NOTE: Even though some of the above "tonal centers" have changed, the scale notes remain the same. Just listen for now. We will explore these sounds in greater detail later.

ALTERNATE C MAJOR SCALE FINGERINGS

Following are some alternate scale fingerings not covered earlier. These are quite challenging and should be practiced only once the others are mastered. Follow the fingerings carefully and practice moving each one of them up and down the fretboard chromatically (one fret at a time).

The diagrams show four alternate C major scale fingerings on a six-string guitar fretboard:

- I Fret:** Notes are B¹, E¹, A¹, G², C², F², D², G², B³, A⁴, D⁴, G⁴, C⁴, E⁴, A⁴. A hand icon labeled "Stretch" points to C².
- VIII Fret:** Notes are C¹, F¹, B¹, E¹, D², G², C², F², A², D², E³, A⁴, D⁴, G⁴, B⁴, E⁴. Hand icons labeled "Stretch" point to C¹ and C².
- III Fret:** Notes are G¹, C¹, F¹, B¹, A², D², G², C², E², A², F³, B⁴, E⁴, A⁴, D⁴, B⁴. A hand icon labeled "Stretch" points to C¹.
- X Fret:** Notes are D¹, G¹, C¹, F¹, E², A², D², G², B², E², F³, C³, F³, B⁴, E⁴, A⁴. Hand icons labeled "Stretch" point to C¹ and C³.

The first two diagrams are labeled "Stretchmania" and "Stretchorama" respectively.

Be careful to play all the stretches as indicated by the fingerings.

PLAYING SCALES HORIZONTALLY

This heading does not mean that these scales are practiced lying down (ha ha). Up to this point all the scale forms studied have been played with the hand crossing strings ceiling to floor.

Now we are going to focus on moving horizontally from one vertical shift form to the next. Therefore there will be at least one shift of hand position for each scale.

1. Make sure to follow each of the scale fingerings very carefully and pay close attention to the shifts themselves.
2. When shifting, don't bend your wrist or change your thumb position. Make the shift with your elbow dropped and move from your shoulder. Even short distance shifts should be made in this way.
3. Above all, don't alter the playing position of your fingers and thumb in relation to each other. Place thumb behind the fingers so fingers and thumb form a cup shape. Fingers attack the strings from above with a hammer-like action, not from under the string or off to the side of it.

Let's try some hands-on scale shifts.

C Major II - V Position

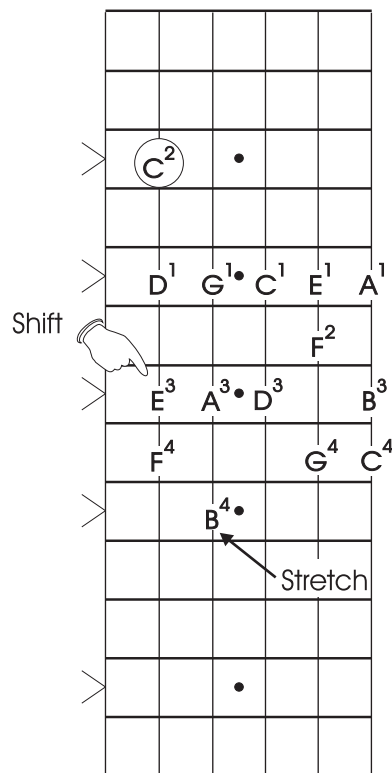
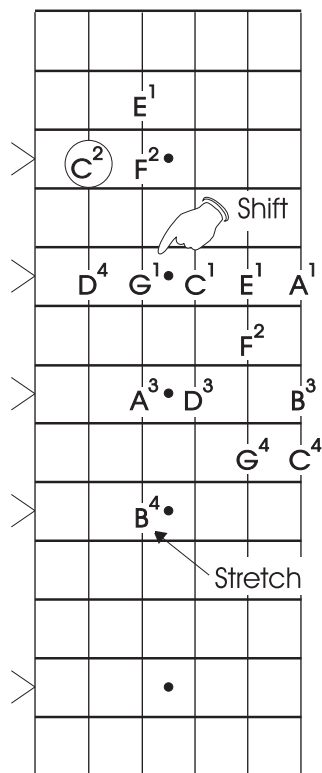
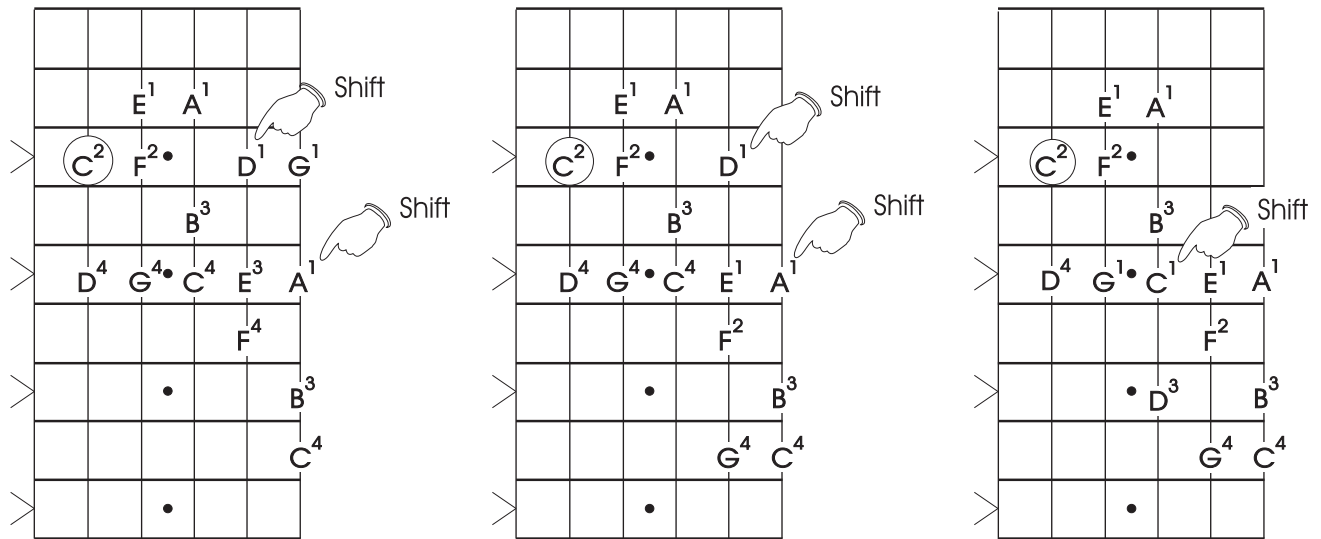

Note that every shift is guided with the 1st finger.
 Fret marks placed at III, V, VII, IX, XII

SCALE SHIFTS - 2-OCTAVE SCALES

C Major I - V Position

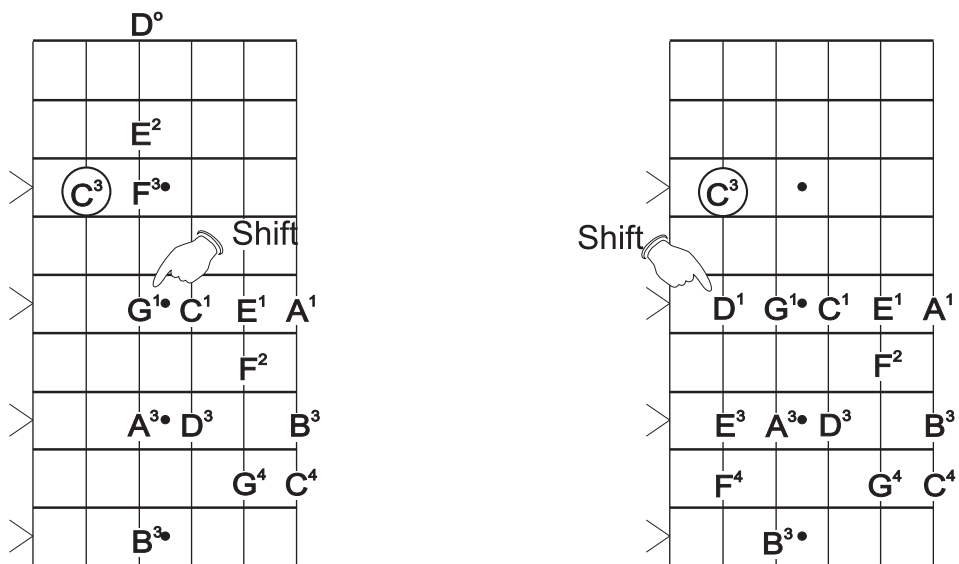
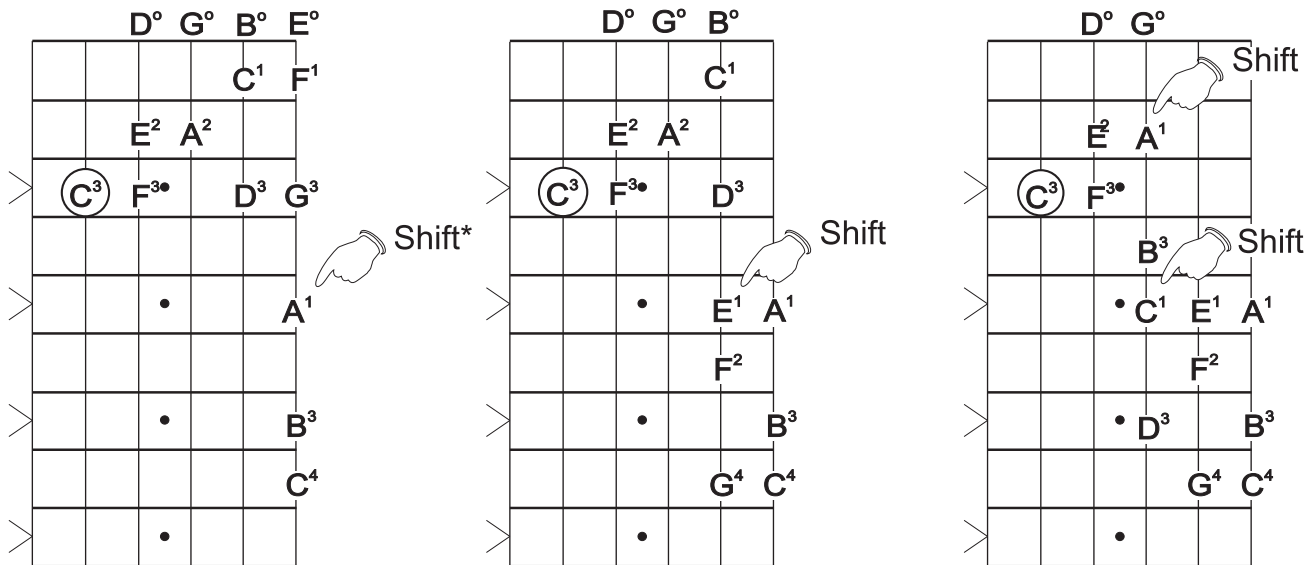

NOTE:

When shifting, don't jump your hand, use your 1st finger as a gliding guide on the string.

C Major II - VII Position

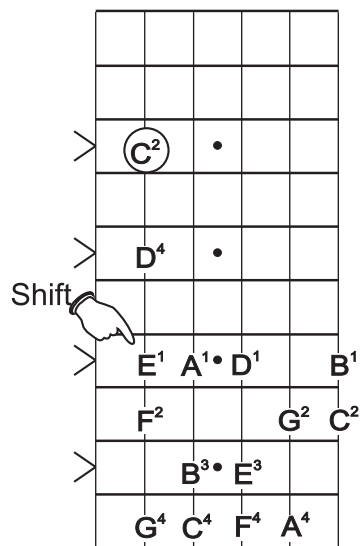
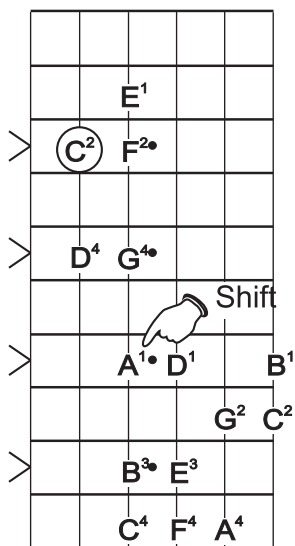
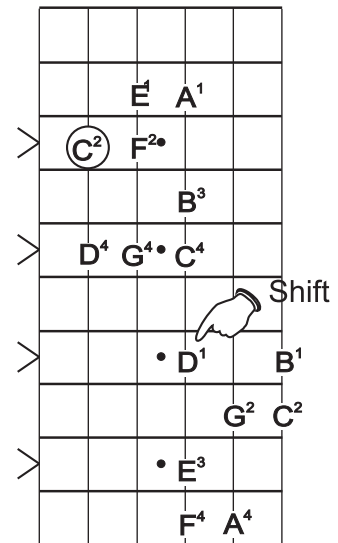
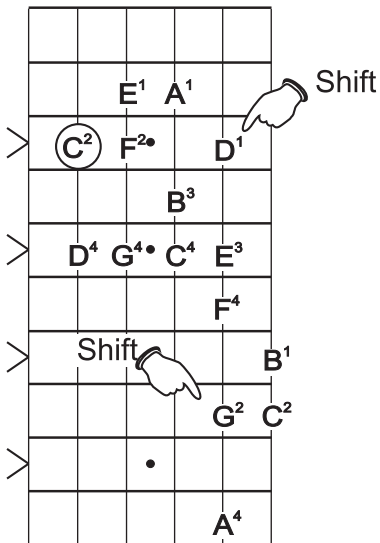
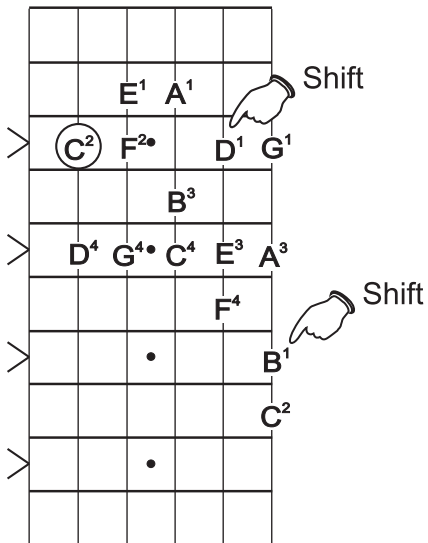

Now extend this idea to positions
 V-VII V-IX VII-IX VII-XII IX-XII
 and any other combinations.

THE G MAJOR SCALE

The G major scale is a T T S T T T S scale beginning on a G note.

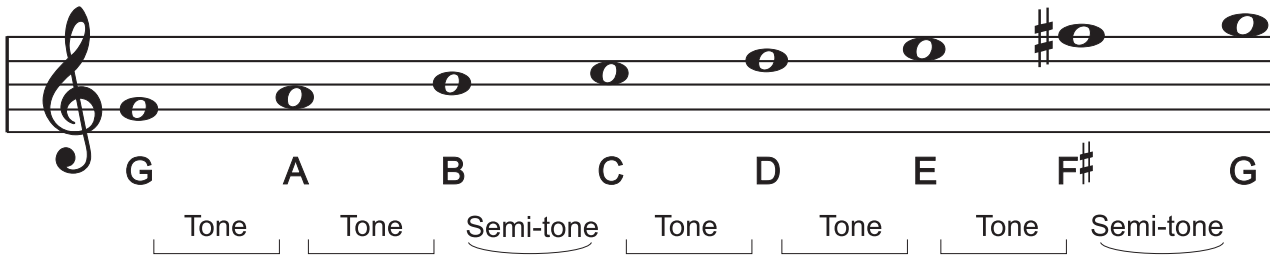

This is a sharp sign. It raises the note a semi-tone.

Notice that the VII degree of the scale is now raised to an F# (sharp) note. This note is an F# in order to maintain the proper relationship of TTSTTTS. If the note of F was note altered to an F#, the scale would be TTSTTST, which is not a major scale. Therefore, the notes in the scale of G major are:



EXERCISE:

Play all the C major scale positions starting on a G note and raise the F to an F#, thereby making a G major scale.

Now, let's examine the G major scale on the fretboard.

THE G MAJOR SCALE

Below are all the notes of G A B C D E F# G wherever they take place on the fretboard. G root notes are in grey circles.

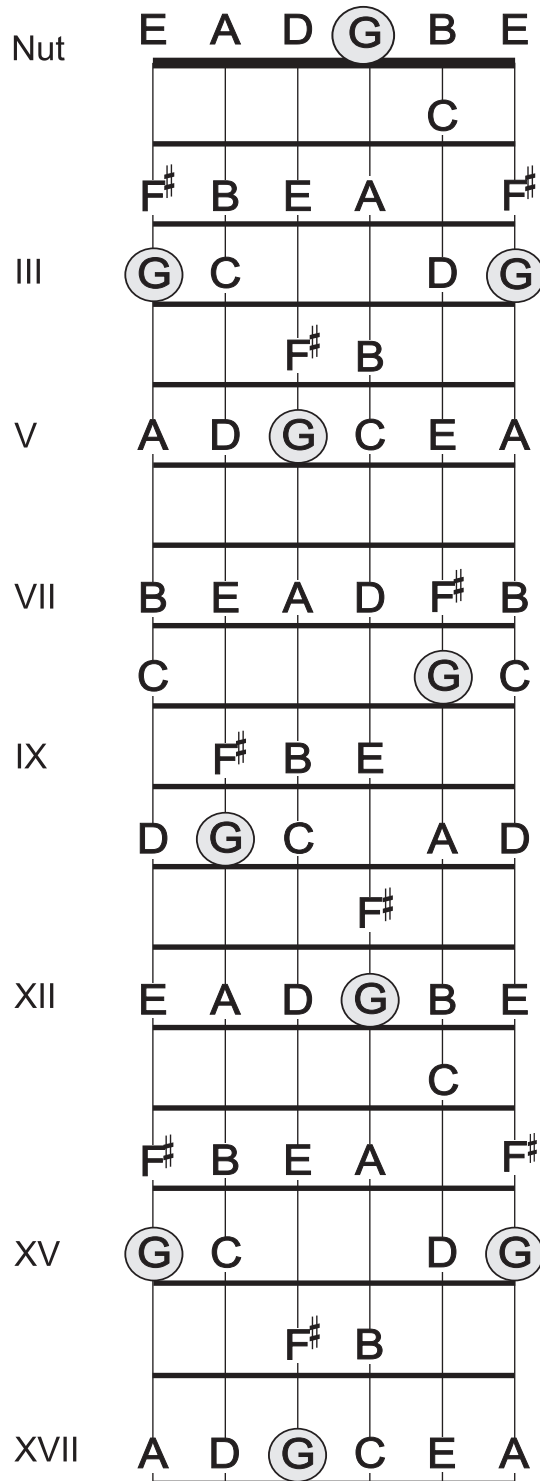

Now as before, let's organize into vertical forms. Note all of these forms are going to be a repeat of C major forms, only in different positions.

THE G MAJOR SCALE

ALL POSITIONS

Chords

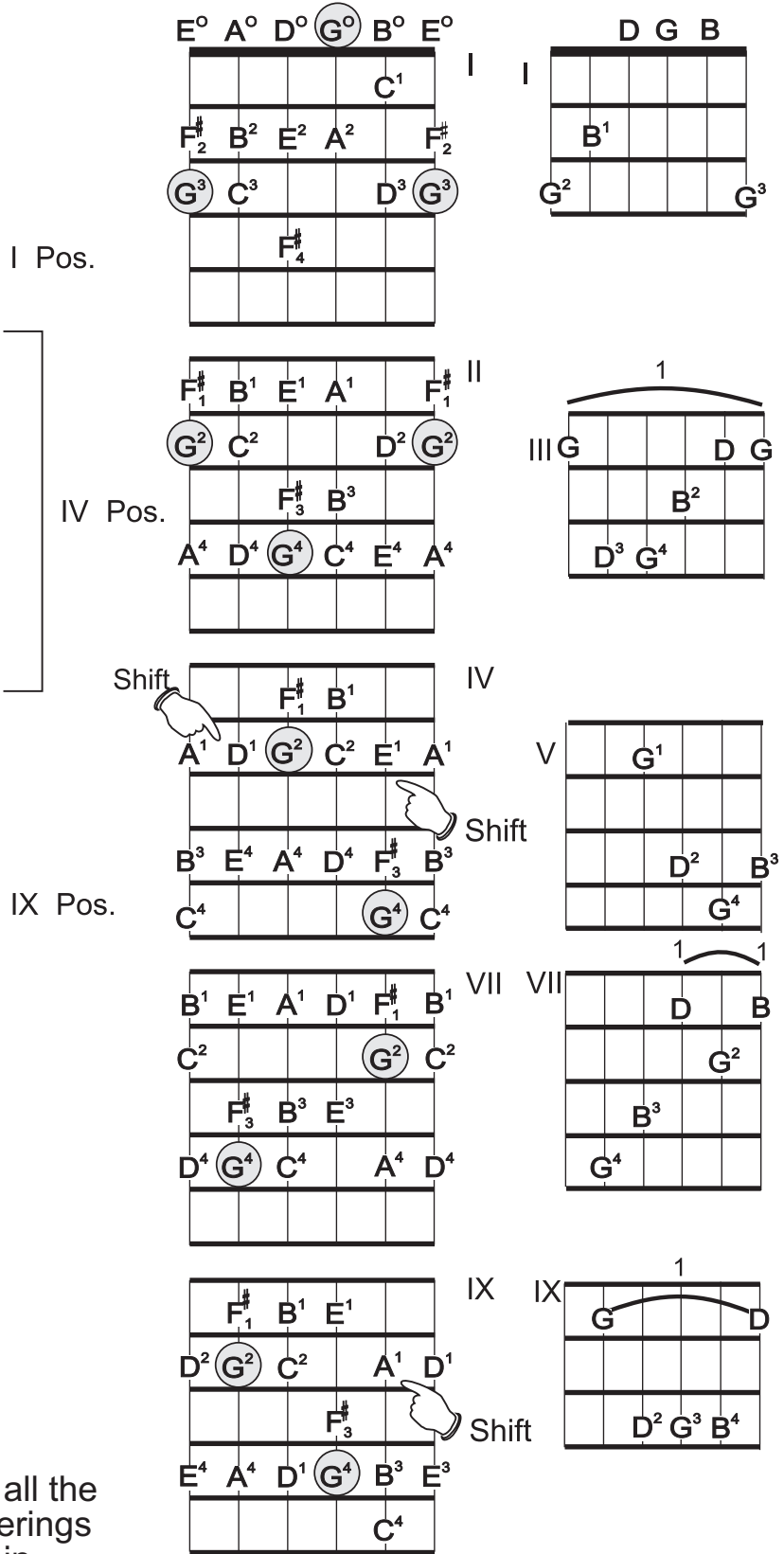
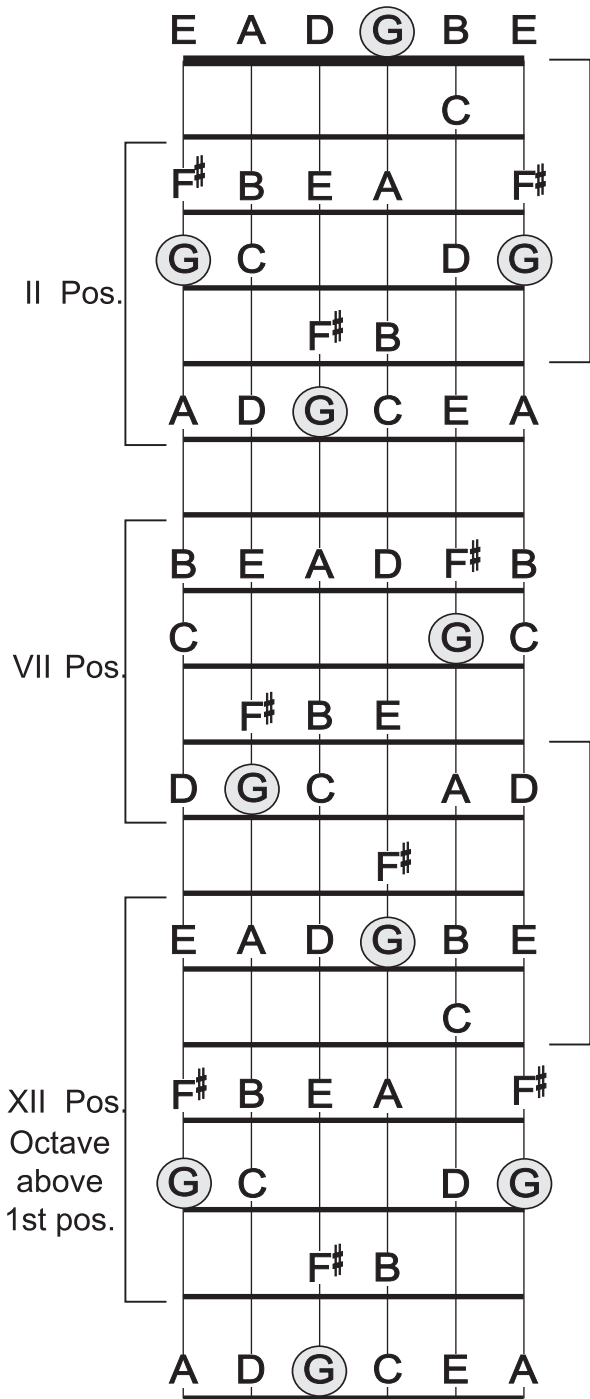

NOTE:

The above scale fingerings are all the same as the C major scale fingerings we have studied except played in different positions.

THE E NATURAL MINOR SCALE

ALL POSITIONS

Chords

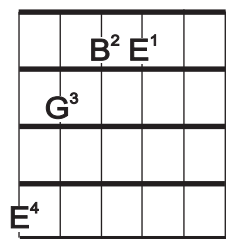
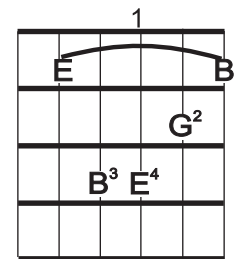
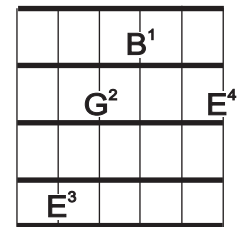
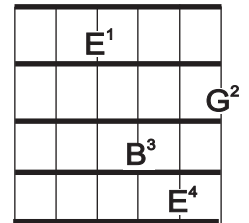
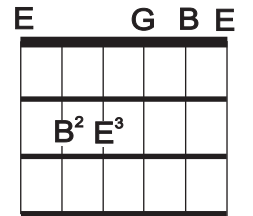
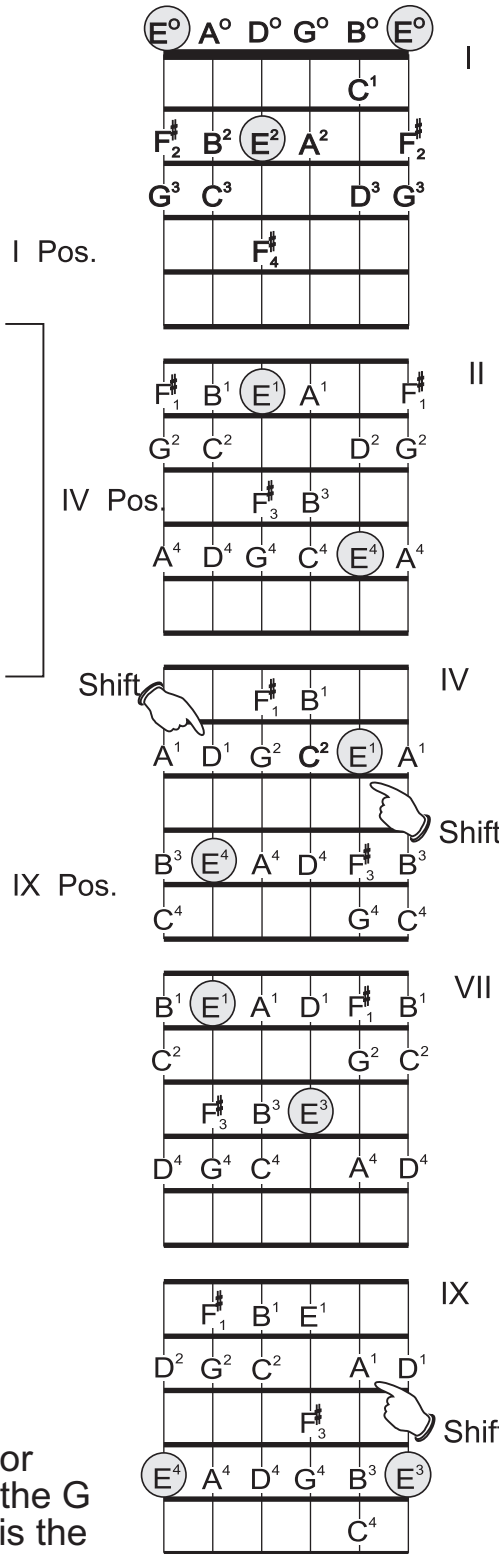
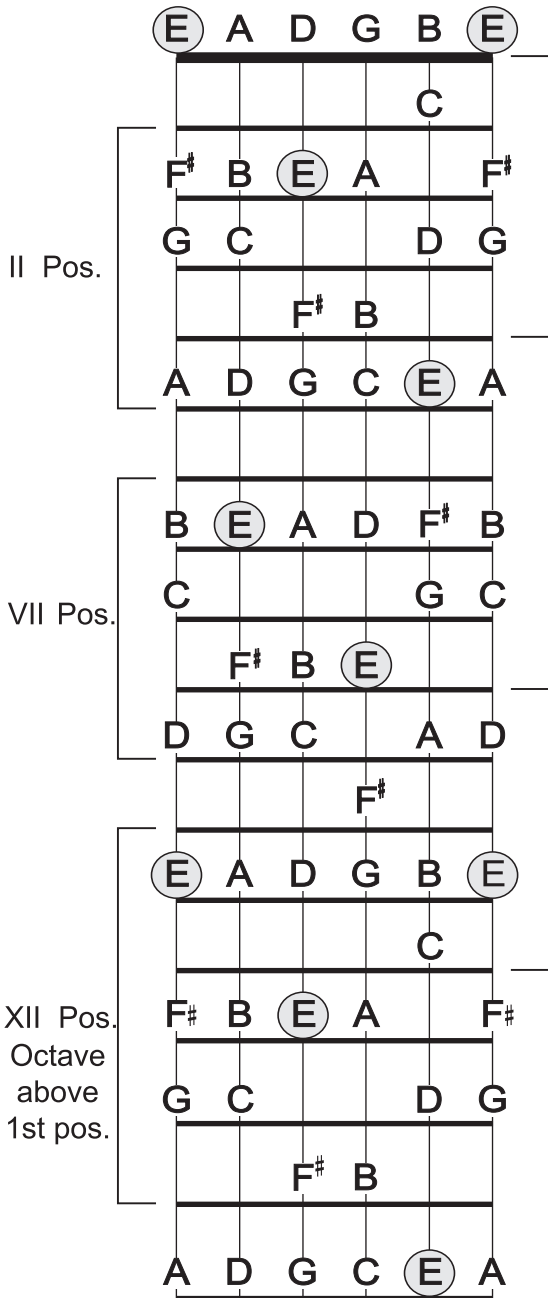

NOTE:

Remember that the E natural minor scale uses all the same notes as the G major scale. The only difference is the tonal centre or the root note, which in this case is E. Be careful to hear and practice all these scales from the root note E.

THE G MAJOR PENTATONIC SCALE

ALL POSITIONS

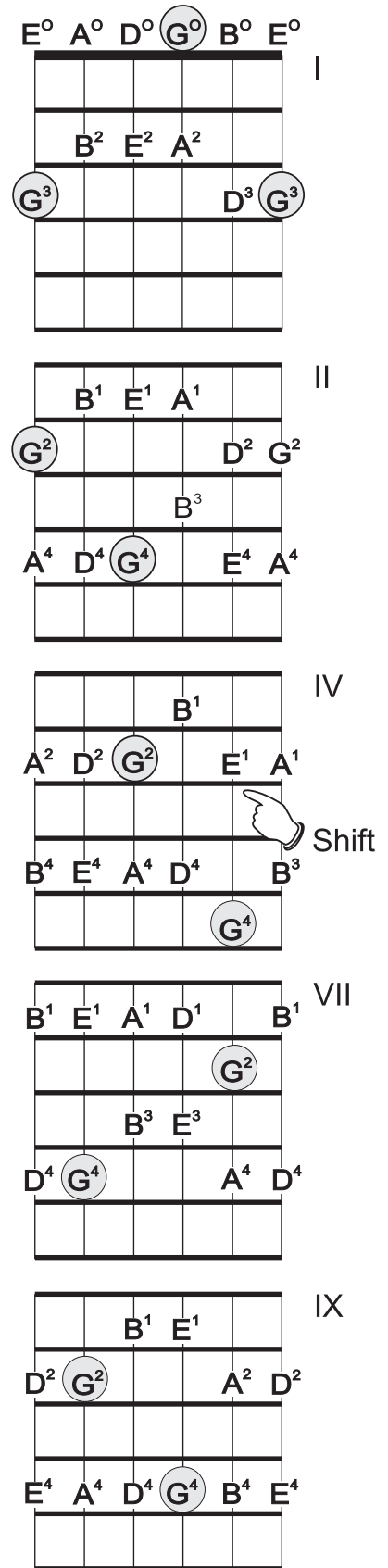
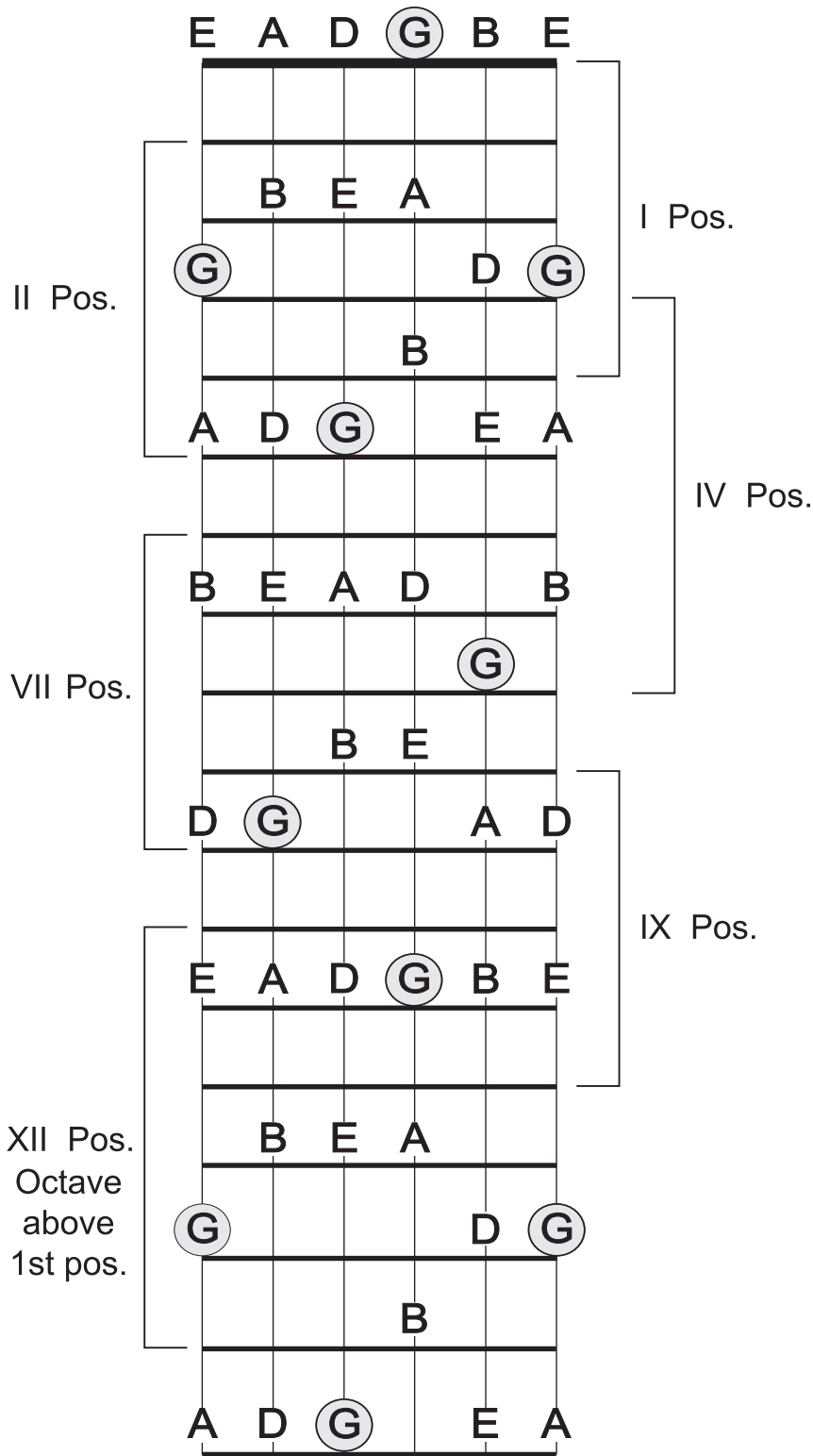

NOTE:

Once you have played all the G major positions then play them all from the root note E. By playing from E as the tonal centre, the sound will be E minor pentatonic.

MOVING AND RENAMING THE VERTICAL SCALE FORMS

On the following pages, we are going to examine the vertical scales as moveable forms.

In the same way a single note can be moved, so too can a scale form be moved. For example, if we move the note of C up a semi-tone, it becomes C \sharp or D \flat . In the same way a whole C major scale fingering can be moved up one fret; it now becomes a C \sharp major or D \flat major scale. (Remember that the notes of the C \sharp and D \flat major scales are the same pitches, although the note names differ, see "enharmonic" in glossary). Therefore, if we extend this logic, all the scale fingerings are moveable. For example, G major moved up one semi-tone will become G \sharp or A \flat , then up one more fret to A major, then A \sharp /B \flat , then B, etc.

As the scale form is moved up and down the fretboard, the scale fingering remains the same and the relationships between the notes stay the same as well. The notes and the scale names, however, change as the pattern is moved. Carefully examine the examples given.

Make sure that in your practice you take the time to move all the scale positions up and down the length of the fretboard. Be sure to make a point of naming each of the scale forms as you move them and keep your fingerings consistent.

Don't let the note names confuse you because ultimately these are all sounds to your ears. There is no doubt that some knowledge of music theory would be a help as you further your study of the guitar. You can study Theory Courses for Guitar at www.MyGuitarPal.com, Beginner, Intermediate, and Advanced Harmony.

The following six examples will make this all clear. It is wise to go through every scale form and move them and rename them. Do the same with the chord forms too.

Root ⑤ String Major Scale

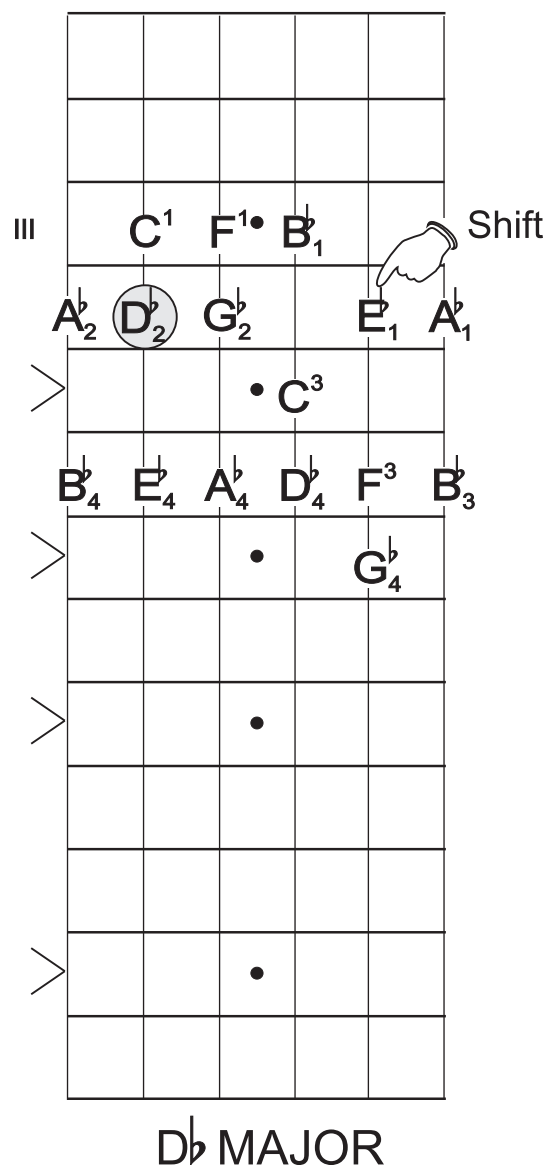
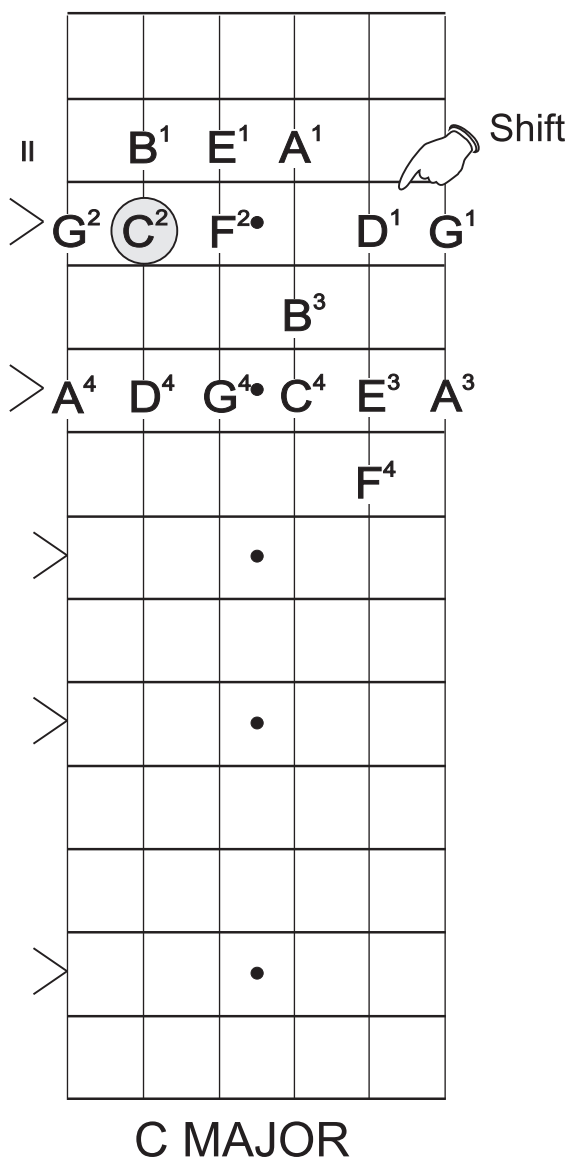

Note: the form is identical for each new scale name

The form is moved chromatically (one fret at a time) up the fretboard.

IV position D Major D E F[#] G A B C[#] D

V position E^b Major E^b F G A^b B^b C D E^b

VI position E Major E F[#] G[#] A B C[#] D[#] E

VII position F Major F G A B^b C D E F

... and so on through the chromatic scale.

Root ⑥ String Major Scale

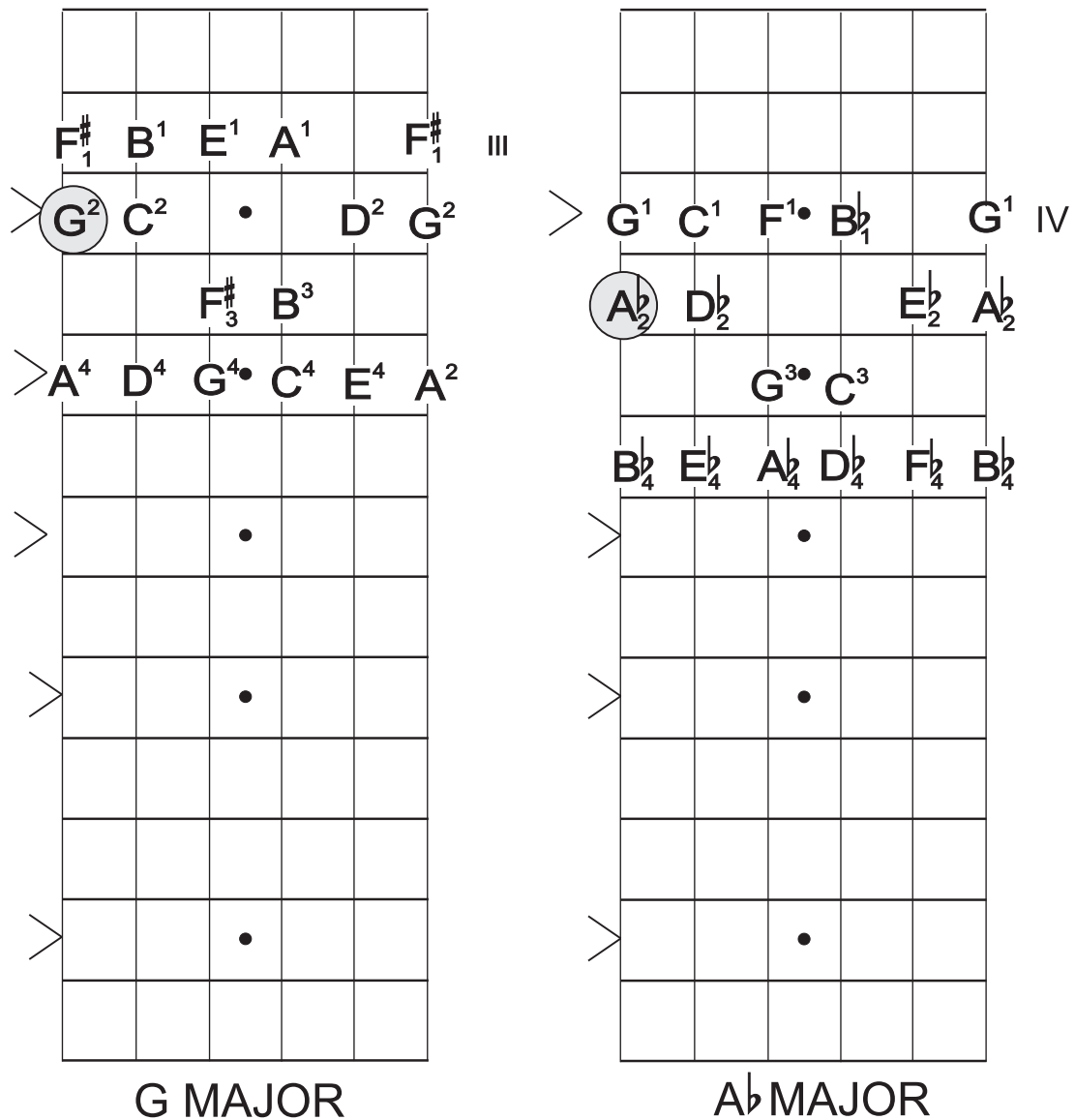

The form is moved chromatically (one fret at a time) up the fretboard.

- V position A Major A B C[#] D E F[#] G[#] A
- VI position B_♭ Major B_♭ C D E_♭ F G A B_♭
- VII position B Major B C[#] D[#] E F[#] G[#] A[#] B
- VIII position C Major C D E F G A B C

and so on...

Root ⑥ String Natural Minor Scale

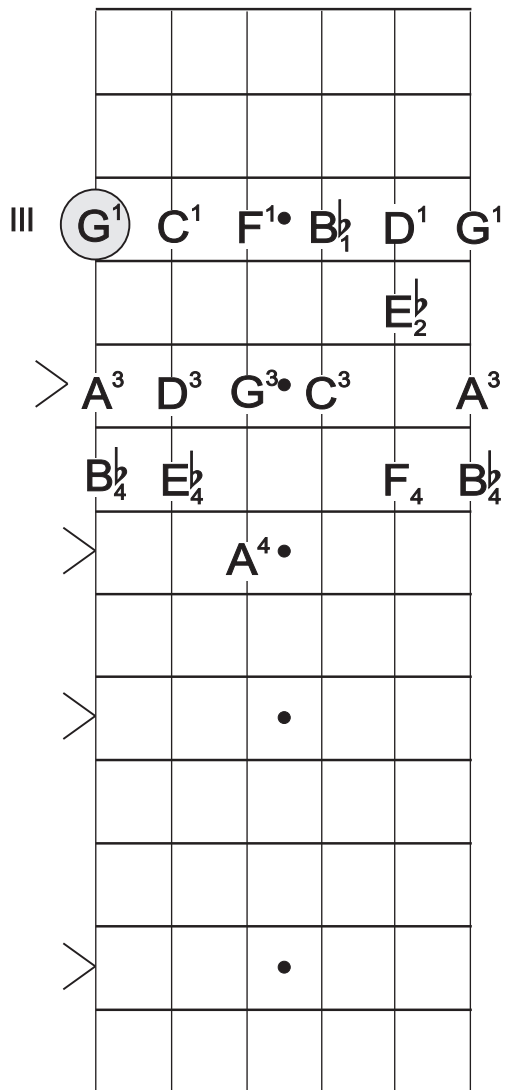

G NATURAL MINOR

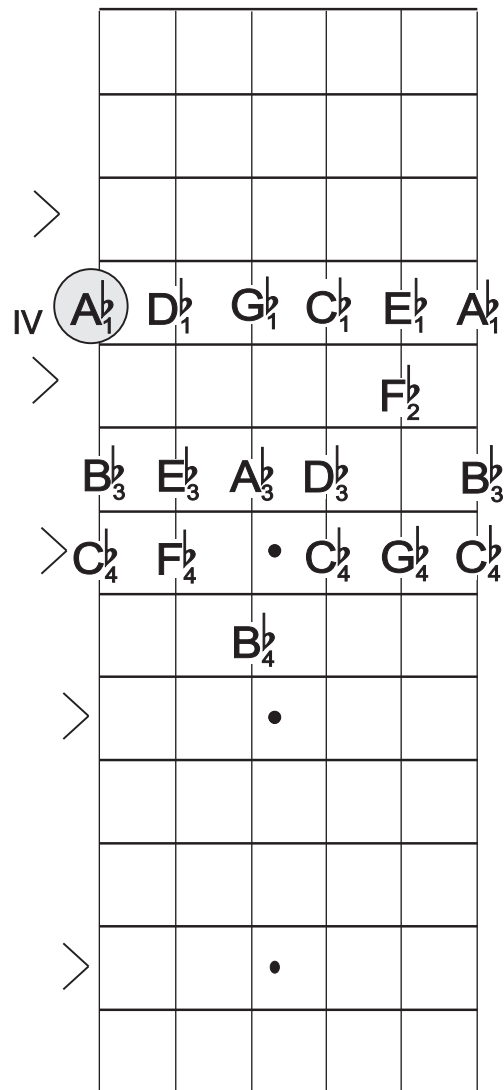

Ab NATURAL MINOR

As the form is moved chromatically (one fret at a time) up the fretboard.

V	position	A Natural Minor	A	B	C	D	E	F	G	A
VI	position	Bb Natural Minor	Bb	C	D	E	F	G	Ab	Bb
VII	position	B Natural Minor	B	C#	D	E	F#	G	A	B
VIII	position	C Natural Minor	C	D	E	F	G	Ab	Bb	C

Root ⑤ String Natural Minor Scale

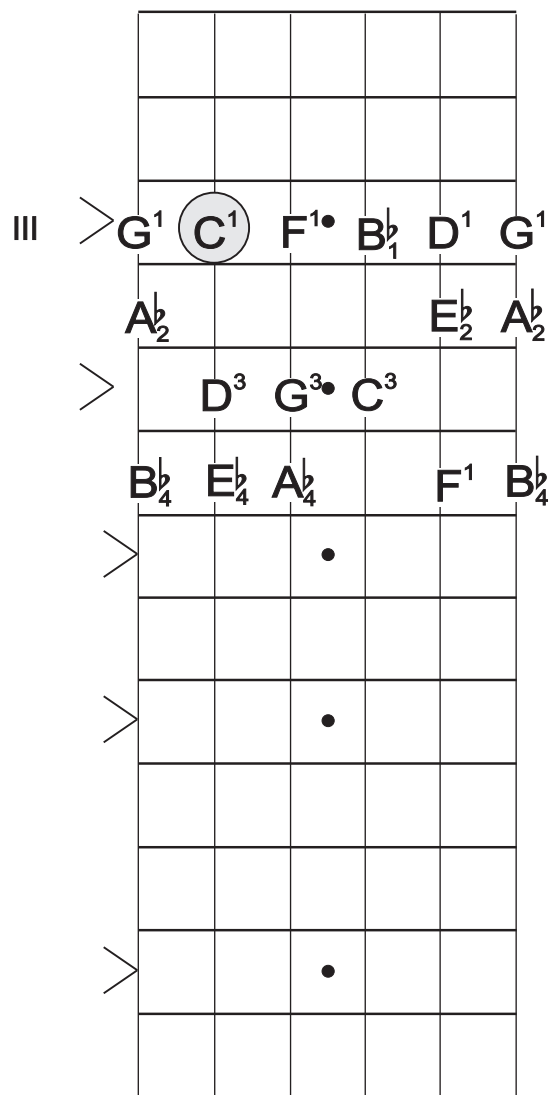

C NATURAL
MINOR

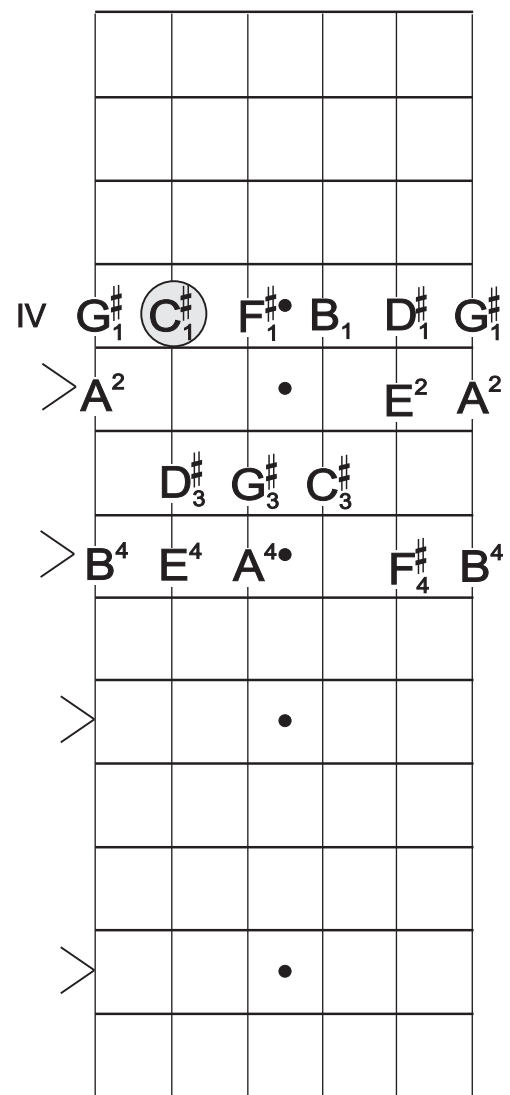

C# NATURAL
MINOR

The form is moved chromatically (one fret at a time) up the fretboard.

- V position D Natural Minor D E F G A B♭ C D
- VI position ♭ E♭ Natural Minor E♭ F G♭ A♭ B♭ C♭ D♭ E♭
- VII position E Natural Minor E F# G A B C D E
- VIII position F Natural Minor F G A♭ B♭ C D♭ E♭ F

Root ④ String Major Pentatonic Scale

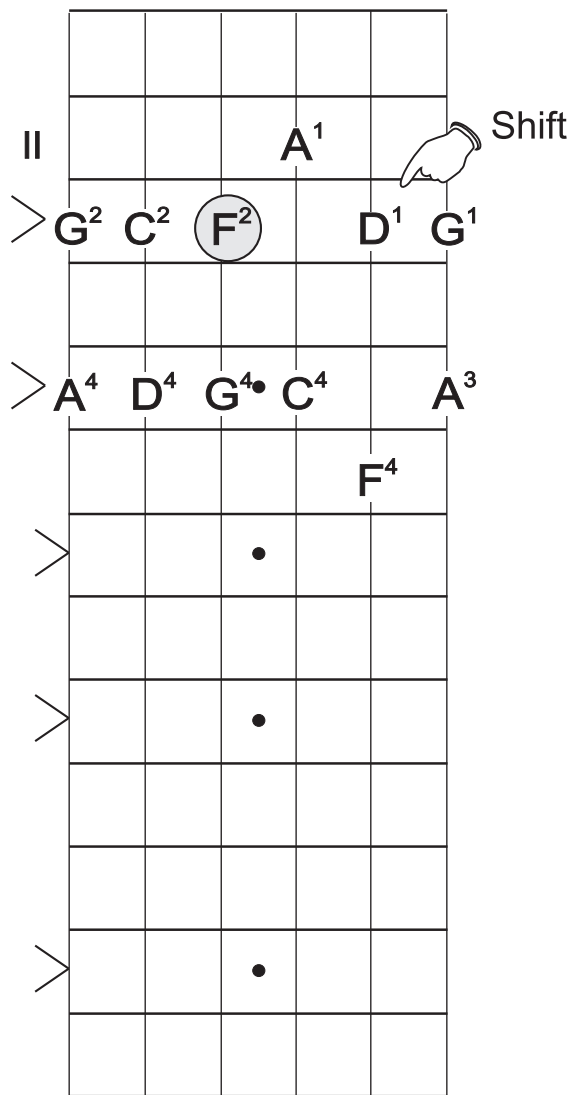

F MAJOR PENTATONIC

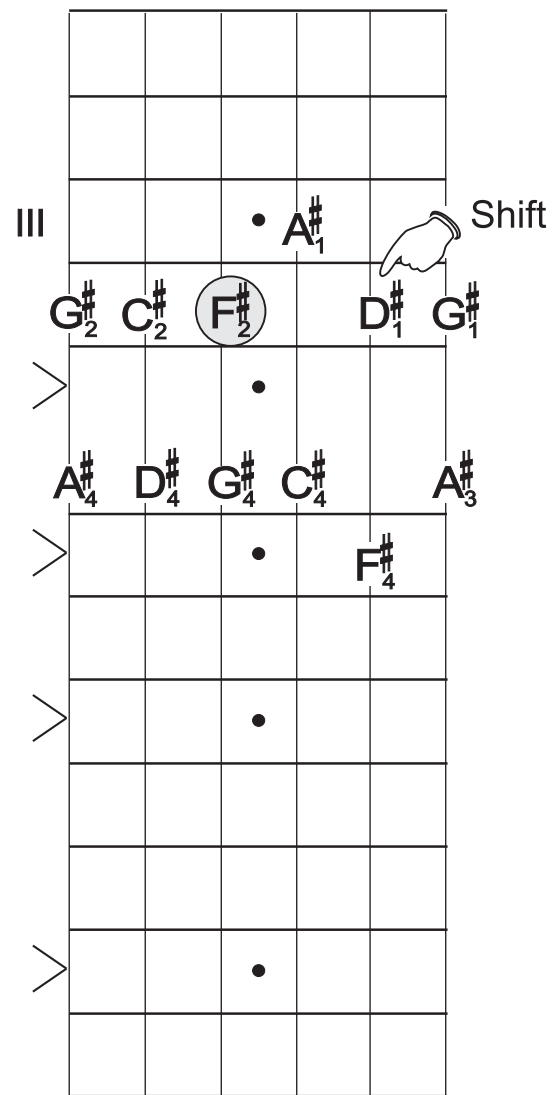

F# MAJOR PENTATONIC

The form is moved chromatically (one fret at a time) up the fretboard.

IV position G Major Pentatonic G A B D E
 V position A♭ Major Pentatonic A♭ B♭ C E♭ F
 VI position A Major Pentatonic A B C# E F#
 VII position B♭ Major Pentatonic B♭ C D F G

Root ⑥ String Minor Pentatonic

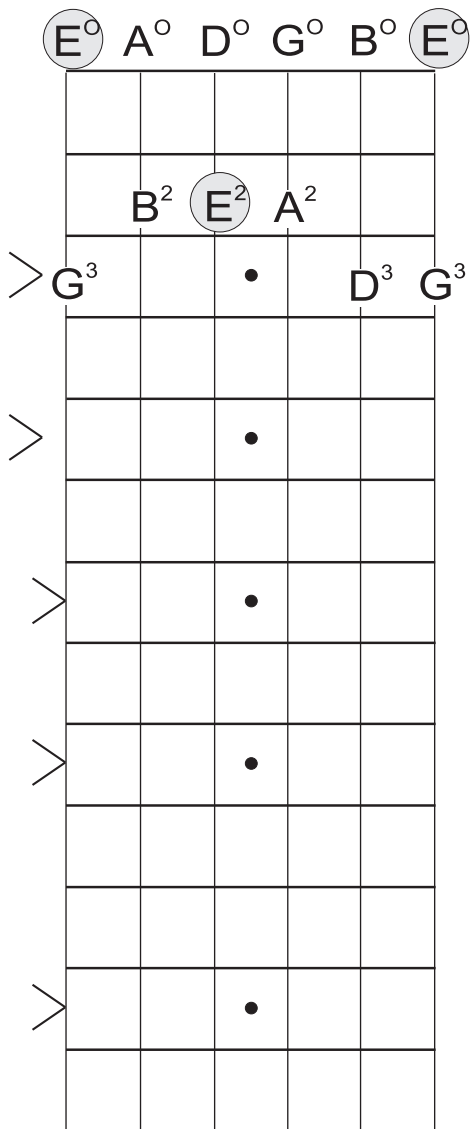

E minor Pentatonic

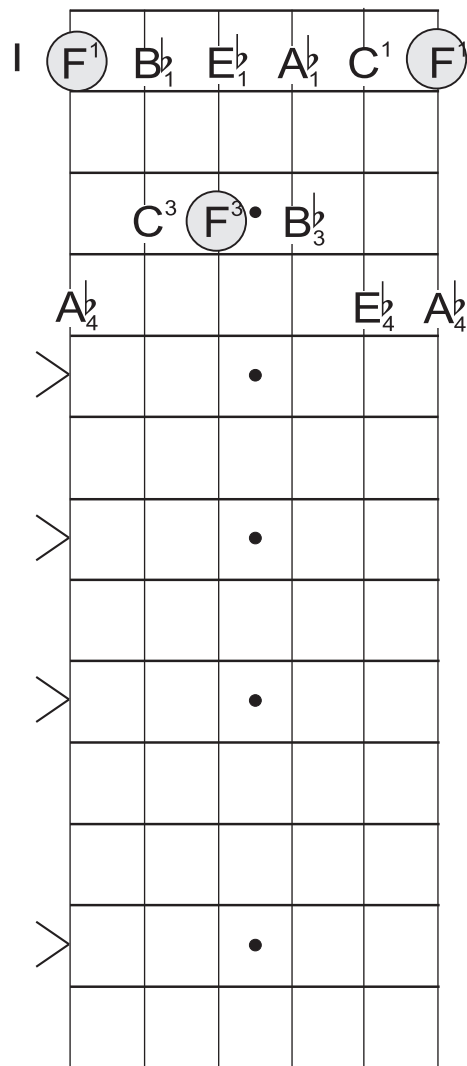

F minor Pentatonic

The form is moved chromatically (one fret at a time) up the fretboard.

- II position F[#] Minor Pentatonic F[#] A B C[#] E
- III position G Minor Pentatonic G B^b C D F
- IV position A^b Minor Pentatonic A^b C^b D^b E^b G^b
- V position A Minor Pentatonic A C D E G

QUESTIONS 4

1. What is the interval between the root and third of the minor pentatonic scale? _____
2. What is the interval between the root and third in the major pentatonic scale? _____
3. What does C/D mean as a chord symbol? _____
4. How many notes are in a G5 chord? _____
5. Moving up chromatically, what note comes after each of the following:

C# _____ E _____ G _____ B _____ A _____
D♭ _____ B♭ _____ F# _____ G _____ A# _____

6. For each of the following notes, name another note with the same pitch, but a different name (enharmonic):

E# _____ D _____ E♭ _____ F# _____ A♭ _____ B♭ _____

7. What does "ascending chromatically" mean? _____

8. What does "descending chromatically" mean? _____

9. Define the following terms:
Low _____
High _____
Range _____
Pitch _____
Pentatonic _____
Chord _____
Scale _____

C	D	___	F	G	___	B	C												
G	A	B	C	D	E	___	G												
A	C	D	___	G	A	___													
F	___	A	___	___	F	___													
D	E	F	G	A	___	___	D												
B \flat	C	D \flat	E \flat	___	___	___	___												
E \flat	E	F	G \flat	G	A	A \flat	___	___	___	___	___	___	___	___	___	___	___	___	___
F \sharp	A	___	___	___	___	___	___												
D \flat	___	F	___	___	___	C	___												
C \sharp	___	E \sharp	___	___	___	___	___												
C	___	E \flat	___	___	___	___	___												
B	C	C \sharp	D	D \sharp	E	___	___	___	___	___	___	___	___	___	___	___	___	___	___
G	A	B	___	E	___	___	___	___	___	___	___	___	___	___	___	___	___	___	___

11. Write the notes of the relative minor scales of the following major scales:

C Major _____

G Major _____

D Major _____

12. Write the notes of the major pentatonic scale in the following keys:

A _____

E _____

G _____

A _____

13. Write the notes of the minor pentatonic scale in the following keys:

C _____

F _____

B \flat _____

MASTER FRETBOARD

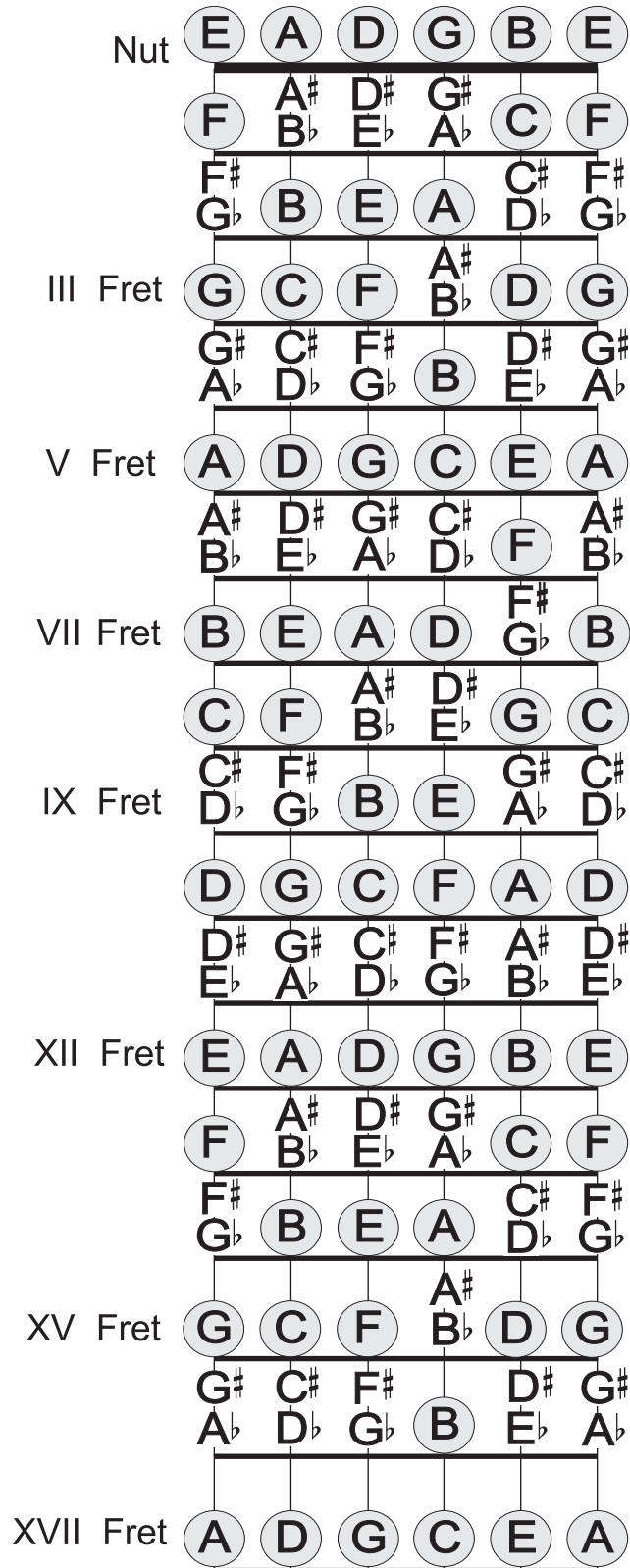

Scale Tonic
or "Key"

MAJOR SCALES REFERENCE SHEET

C	D	E	F	G	A	B	C	No Sharps No Flats
G	A	B	C	D	E	F [#]	G	1 Sharp
D	E	F [#]	G	A	B	C [#]	D	2 Sharps
A	B	C [#]	D	E	F [#]	G [#]	A	3 Sharps
E	F [#]	G [#]	A	B	C [#]	D [#]	E	4 Sharps
B	C [#]	D [#]	E	F [#]	G [#]	A [#]	B	5 Sharps
F[#]	G [#]	A [#]	B	C [#]	D [#]	E [#]	F [#]	6 Sharps
C[#]	D [#]	E [#]	F [#]	G [#]	A [#]	B [#]	C [#]	7 Sharps
C^b	D ^b	E ^b	F ^b	G ^b	A ^b	B ^b	C ^b	7 Flats
G^b	A ^b	B ^b	C ^b	D ^b	E ^b	F	G ^b	6 Flats
D^b	E ^b	F	G ^b	A ^b	B ^b	C	D ^b	5 Flats
A^b	B ^b	C	D ^b	E ^b	F	G	A ^b	4 Flats
E^b	F	G	A ^b	B ^b	C	D	E ^b	3 Flats
B^b	C	D	E ^b	F	G	A	B ^b	2 Flats
F	G	A	B ^b	C	D	E	F	1 Flat

Note that some keys are "enharmonic." Ex. D[#] and C^b or G^b and F[#] This means the notes are the same but they have different names.

GLOSSARY OF TERMS

Arpeggio

A broken chord, the notes of a chord played individually.

Ascending

Moving in an upward position, moving higher in pitch. On the fretboard toward the body or toward the floor.

Chord

Three or more notes sounded simultaneously.

Chromatic Scale

A series of notes ascending or descending in semi-tones. A complete octave consists of 12 semi-tones.

Descending

Moving lower in pitch. On the fretboard away from the body or toward the ceiling.

Diatonic

Music predominantly using notes from a scale. A passage using the notes C D E, D F A would be diatonic. C D \sharp E, D \sharp F A \flat would not be diatonic, these notes would be called chromatic.

Enharmonic

Notes that are the same pitch (sound) but have a different name, e.g. A \sharp and B \flat or G \sharp and A \flat . Same note, different name.

Fingering

Numbers above or below notation indicating which finger to be used for that note, indications in music notation, tablature or fret graphs which suggest the most economical approach to a fingering problem.

Half-step

The shortest distance between two notes on the fretboard, also known as "semi-tone" or a minor second. There are smaller distances, quarter tones, but these are heard mainly in oriental and middle eastern forms and are impractical to write in our notation, although "bluesy" note bends are sometimes in quarter tones.

Interval

The distance between two notes, named by numbers and major, minor, diminished, augmented. e.g. Major 3rd, minor 7th, augmented 5th, etc. These are named by a system of numbers - 1 to 13, and types - major, minor, diminished, augmented.

Key

The tonal centre of a piece of music. The note around which all others gravitate; key centre.

Major Scale

A Tone Tone Semi-tone Tone Tone Tone Semi-tone scale beginning on any note. The distance between the starting note and the 3rd note is a major 3rd.

Modes

A series of scale sounds, each with a different relationship of tones and semi-tones.

Ionian	T T S T T T S
Dorian	T S T T T S T
Phrygian	S T T T S T T
Lydian	T S T T S T T S
Mixolydian	T T S T T S T
Aolian	T S T T S T T
Locrian	S T T S T T T

Natural Minor Scale

A Tone Semi-tone Tone Tone Semi-tone Tone Tone scale. Also known as the "Relative Minor" because it shares all the notes of the Major Scale starting three above it's starting note.

Octave

The closest distance between two notes of the same name.

Pentatonic Scale

A five note scale with no Semi-tones. Can be major or minor depending on the starting (tonic) note. e.g. C D E G A (major), or A C D E G (minor).

Pitch

The location of a musical sound as determined by its frequency (number of vibrations per second).

Position

Where the fingering hand is placed, designated by the fret number.

Power Chord

A two-note chord, a perfect 5th apart, ex. C-G or F-C. Sometimes designated as C5 or F5. The notes may be doubled as well, ex. CGC or GCGC for a bigger sound.

Range

Refers to the lowest to highest note an instrument or voice is capable of playing or singing.

Root/Tonic

The first note of a key or scale to which all other notes gravitate or resolve.

Scale Form

A guitarism referring to scale type and fingering.

Semi-tone

See "half-step"

Shift

Change of hand position.

Staff

The lines and spaces on which musical notation is written.

Step

Also known as "whole step" or "whole tone", the distance between two notes consisting of two half steps.

Tempo

Designated by speed markings, ex. Allegro, Largo, Moderato, etc.

Tonal Centre

The note around which all the other notes in a composition gravitate. Also, "key centre", tonic, "root".

Tone

Also known as "whole tone" or "whole step" or interval of a major 2nd, consisting of two half-steps.

Triad

A three-note chord consisting of a root, the third and fifth. There are four basic kinds of triads; major, minor, diminished and augmented. See "TRIADS" in this series for a more detailed explanation.

Triplet

A group of three notes played in place of two of the same kind, indicated by a small 3.

Twelve Bar Blues

The most common type of blues progression. Typically uses the I IV V chords. Form is 12 measures long before repeating.

Whole Tone

See "Tone".

Answers

Questions 1 Pg 8

1. A scale is a group of related notes organized in an ascending or descending order from a starting note.
2. A tone is a major 2nd, or two half-steps or a semi-tone.
3. A semi-tone is the shortest distance between two notes.
4. 8
5. 7
6. major and minor
7. T T S T T T S
8. Root means tonic or key centre
9. Tonic means root or tonal centre
10. Octave
11. Yes
12. No
13. Higher
14. Lower
15. A major
16. About 3 1/2 octaves

Questions 2 Pg 22

1. The relationship between the notes is different (tones & semi-tones)
2. Major sound is bright, happy, fire engine red, etc.
3. Bright
4. Minor
5. A
6. T S T T T T S
7. They share the same notes
8. Between 3rd and 4th degrees
9. Between 2nd & 3rd degrees
10. Cmaj Fmaj Gmaj Emin Amin Dmin

Questions 3 Pg 36

1. 5
2. IV and VII
3. There are none.
4. 3
5. 4
6. Yes
7. What rock 'n roll guitar solo doesn't? (at least in part)
8. The need for resolution of the semi-tones is eliminated.
9. It still has the major 3rd.

Questions 4 Pg 60

1. Minor 3
2. Major 3
3. C chord with D bass
4. 2
5. C# to D E to F G to G# B to C A to B Db to D Bb to B F# to G G to G# A# to B
6. E#-F D-Ebb Eb-D# F#-Gb Ab-G# Bb-A#
7. Ascending chromatically - moving upward by half-step (semi-tone).

8. Descending chromatically - moving downward by half-step (semi-tone).

9. See Glossary of Terms

10. C D E F G A B C
G A B C D E F G
A C D E G A
F G A C D F
D E F G A B C D
Bb C Db Eb F G A Bb
Eb E F Gb G Ab A Bb B C Db D Eb E
F# A B C# E F#
Db Eb F Gb Ab Bb C Db
C# D# E# F# G# A# B# C#
C D Eb F G A B C
B C C# D D# E F F# G G# A A# B
G A B D E G
11. C major - A minor - A B C D E F G# A
G major - E minor - E F# G A B C D# E
D major - B minor - B C# D E F G A# B
A major - F minor - F G Ab Bb C Db E F
12. A major pentatonic - A B C# E F# A
E major pentatonic - Eb F G Bb C Eb
G major pentatonic - G A B D E G
A major pentatonic - Ab Bb C Eb F Ab
13. C minor pentatonic - C Eb F G Bb C
F minor pentatonic - F Ab Bb C Eb F
B minor pentatonic - Bb Db Eb F Ab Bb
E minor pentatonic - E G A B D E

ABOUT THE AUTHOR

Lloyd English studied with some of the most recognized teachers and performers in North America including Howard Roberts, Tony Braden and Bruce Clausen as well as workshops with Joe Pass, Herb Ellis and David Russell, and private classical guitar studies with Eli Kassner, Robert Jordan, Robert Feuerstein and Dr. Alex Dunn.

Lloyd's teaching appointments have included the Kassner Guitar Academy, Toronto and the Vancouver Academy of Arts as well as his own studios.

He completed the Hindemith Harmony Method with Dr. Samuel Dolin (Royal Conservatory of Music), the Delamont Method with Darwin Aitken, Mr. Delamont's successor as well as the Berklee Method with Steven Brundage, student of William Leavitt.

Lloyd has been a working musician all his life and has performed, recorded and produced music in a range of styles, his work has been played on syndicated radio and television networks worldwide. Today Lloyd continues to perform, record and teach and is currently working on an album of original compositions for guitar while being the programs director of My Pal Online Education.

During his teaching career Lloyd has taken students from novice to professional level performing musicians with a unique methodology of integrated functional understanding that translates to an ability to speak the musical language clearly and creatively through the guitar.